

**Antennas:
Special Issue**

02636

JUNE 1979 / \$1.25

HAM RADIO HORIZONS

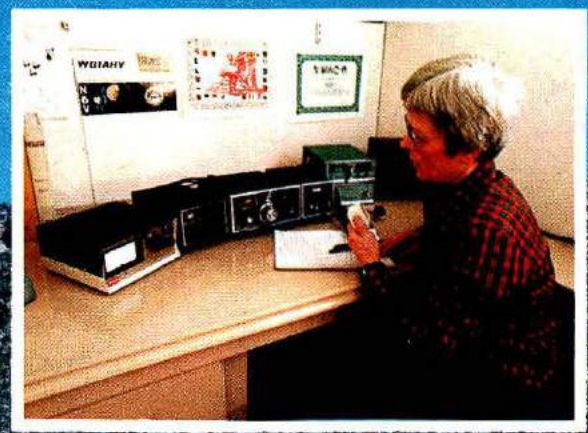

HAM RADIO HORIZONS - JUNE 1979

**FINDING LOW-COST ANTENNA
HARDWARE**
BUILD A MINI RECEIVING ANTENNA
WØROF's SECRET ANTENNA
PLUS OTHER FEATURES





Memo from **Drake**

160 Meter Enthusiasts...

Has Drake got a SECRET WEAPON for you!

DRAKE MN-2700, THE 2 kW ANTENNA MATCHING NETWORK —

With its truly unique antenna feed switching design, the MN-2700 is an instrument that will completely change the mode of a balanced-line fed 135 foot doublet to a special configuration that provides very effective 160 meter performance. And best of all, it's done with the simple flip of a switch on the front panel.

Consider a typical all-band antenna set-up — a 135 foot doublet, center-fed with 60 to 70 feet of balanced line at a height of 45 to 60 feet. The Drake MN-2700/B-1000 will match this as a true balanced system on 80 thru 10 meters.

But what about 160 meters? Many amateurs recommend tying the feeders together and using the antenna as a vertical with a "top-hat". In fact, we suggest this ourselves in our manual.

However, the use of this or any vertical assumes you have a good ground or radial system for efficient operation. If you do not have enough room or do not wish to install such a radial system, performance may suffer. And if you do have radials, you still have to change the feeder connections each time you operate on 160 meters.

On the other hand, when you use the MN-2700/B-1000, simply leave the feeders in the balanced connection as you would for 80 thru 10, and move the special antenna selector switch to Position No. 4. This automatically converts half of the antenna and feedline to an inverted "L", fed through a 4:1 impedance transformer, with the other half operating as a counterpoise.

This system offers the convenience of "stay in your chair" operation, while providing an effective means of working 160 meters with a relatively small antenna.

The Drake MN-7 offers the same special switching design, and is rated for 250 watts output.



Prices and specifications subject to change without notice or obligation.

For a FREE Drake Full Line Catalog contact your favorite Drake Dealer.

R. L. DRAKE COMPANY



540 Richard St., Miamisburg, Ohio 45342
Phone: (513) 866-2421 • Telex: 288-017

WHEN OUR CUSTOMERS TALK...WE LISTEN.

DS3100 ASR

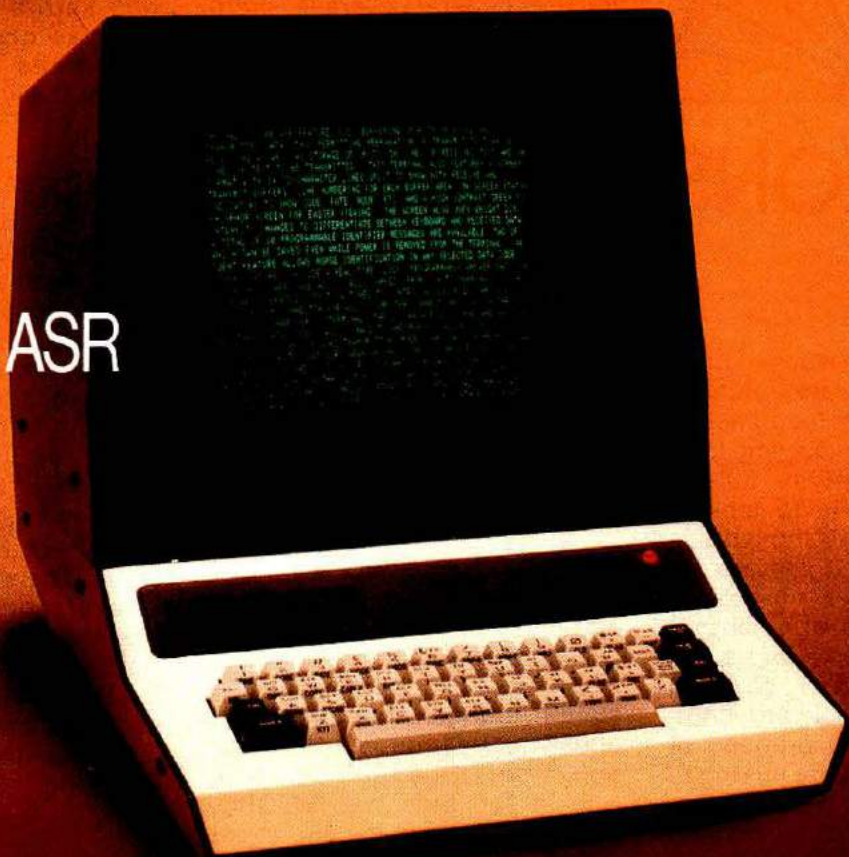

We've Been Taking Notes.

Combining your ideas with some of our own, we've come up with what has to be the most advanced and convenient terminal available. These are some of the conveniences you can now enjoy by putting the DS3100 ASR in your RTTY and CW station:

ASR Operation (Compose your transmission WHILE receiving)

- 150-line Receiver Buffer
- 50-line Transmit Buffer
- Split Screen to Show Buffers
- Internal Real-Time Clock
- 10 Programmable Messages
- Automatic Answer-Back (WRU)
- Morse, Baudot, or ASCII Operation
- RTTY and CW Identification
- Full 128-Character ASCII
- 110-9600 baud ASCII
- 60-130 WPM Baudot
- 1-175 WPM Morse

Write or call for the DS3100 ASR specifications and see how YOU have helped design the new standard in amateur radio terminals.



HAL COMMUNICATIONS CORP.
Box 365
Urbana, Illinois 61801
217-367-7373

For our European Customers Contact:
Richter & Co., Hannover
I.E.C. Interelco, Bissone

THIS MONTHS

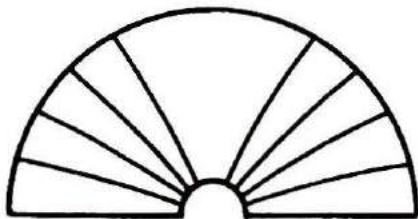

HORIZONS

Antenna Hints and Hardware

There are as many ways to build antennas as there are antennas to build, and every ham has his own pet tricks for putting it all together. One sure-fire trait of the experimenter is to look at anything and everything with an eye toward what it can do for that new beam — no matter what the gadget's original purpose. W1SL passes along a few tips from his notebook, covering many years of backyard engineering. You'll be surprised at what antenna parts are lurking in your nearby auto-parts store, plumber's supply house, or hardware emporium.

Midnight Antenna Party

Apartments and condominiums are a modern solution to the housing problem, but the lease usually spells doom for an antenna enthusiast. The urge to create (and to work DX) can be driven underground, but it smolders in the dark, searching for the way out. W0ROF tells how he won, and his tale is required — and delightful — reading for all you cramped-space captives.

Short Receiving Antenna

It's difficult to make a shortened antenna perform in a conventional manner when it must be bent, twisted, or hidden in the confines of a small house or apartment. However, if you forget about the way an antenna

should work and make it behave like a probe, sampling the voltages around it, then things begin to happen. Author Blakelee tells you about a compact unit that can be assembled in a few evenings; it will do wonders for that general-coverage short-wave receiver, and for listening on the ham bands as well.

Antenna Switch

It is a rare Amateur who does not need or desire several antennas — even a beginner tries to be the first on his block with more than one. However, a look at the cost and bulk of several coaxial feedlines can give pause to almost anyone. Here's a scheme that will really put a single coaxial cable to work for you, with a couple of safety features thrown in.

Logbook Commentary

A look at the logbook of many Amateur stations usually reveals the bare essentials of contacts made. To the operator of the station, entries can trigger memories which far outlast the duration of the QSOs. Author Jablin, who at the time was W2QPQ, gives you a little insight about reading between the lines. Not world-shaking DX, but contacts memorable in their own right, proving that Amateur Radio is a wonderful medium for relaxing and getting to know your fellow man.

More Delta-Loop Details

Antennas are always a popular subject, and response to the delta-loop article in our June, 1978, issue was very gratifying. The author of that article, G3LLL, couldn't leave well-enough alone, and has added two more bands to his array. It's not a difficult task and the results are well worth the effort. See how it's done on page 42.

More Tales Of The Early Days Of Radio

You've surely heard of Plymouth, Massachusetts, and

Plymouth Rock. It marked the beginning of America in 1620. Now you can read about another beginning — tales of what happened in Plymouth around the turn of the century in the world of early radio, or wireless, as it was known then. Author Alan Douglas gives some amusing anecdotes about the period before today's Amateur bands.

The Cover

William LeBaron, W0MTK, sent us this photograph of his beautiful location and antenna installation. It appears that Bill is into several facets of Amateur Radio — that beam covers several bands, and there's an inverted-V hanging off the tower too. A sharp eye will notice a vertical antenna for vhf work as well. The message is that this is *Ham Radio Horizons'* annual antenna issue. The station shown in the inset is not Bill's, but rather is one we added to show a slice of Amateur Radio indoors — meaning that something must be connected to both ends of the coaxial cable to enjoy the fun of hamming.

HAM RADIO HORIZONS June 1979, Volume 3, Number 6. Published monthly by Communications Technology, Inc., Greenville, New Hampshire 03048. Telephone (603) 878-1441. Second Class Postage paid at Greenville, New Hampshire and at additional mailing offices. ISSN 0147-8818. Address all editorial and advertising correspondence to Greenville, New Hampshire 03048.

Subscription price: Domestic, one year, \$10.00; two years, \$18.00; three years, \$24.00. Canada and Worldwide add \$2.00 per year, payable in United States funds please.

Subscription inquiries and changes of address should be directed to *Ham Radio Horizons*, Greenville, New Hampshire 03048. Please include address label from most recent issue if possible.

NEW MFJ-962 1.5 KW Versa Tuner III

For \$159.95 you can run up to 1.5 KW PEP and match everything from 1.8 thru 30 MHz: coax, balanced line, random wire. Built-in balun. SWR, dual range forward and reflected power meter. Flexible six position antenna switch. Outstanding value.



Where else can you get a 1.5 KW Tuner with SWR, dual range forward and reflected power meter, antenna switch and balun for only . . .

\$159⁹⁵

1.5 KW PEP

The NEW MFJ-962 1.5 KW Versa Tuner III lets you run up to 1.5 KW PEP and match any feedline continuously from 1.8 to 30 MHz: coax, balanced line or random wire.

This gives you maximum power transfer to your antenna for solid QSO's and attenuates harmonics to reduce TVI and out-of-band emission.

An accurate meter gives SWR, forward, reflected power in 2 ranges (2000 and 200 watts).

A flexible six position antenna switch lets you select 2 coax lines thru tuner or direct, or random wire and balanced line.

dom wire and balanced line.

A new all metal, low profile cabinet gives you RFI protection, rigid construction, and sleek styling. Black finish. Black front panel has reverse lettering. 5x14x14 inches. A flip down wire stand tilts tuner for easy viewing.

Efficient, encapsulated 4:1 ferrite balun. 500 pf, 6000 volt capacitors, 12 position inductor. Ceramic rotary switch. 2% meter.

Built-in quality. Every single unit is tested for performance and inspected for quality. Solid

American construction, quality components. One year limited warranty.

For your nearest MFJ dealer, call toll-free 800-647-1800. Stop by your dealer. Compare it feature for feature with other tuners. Compare its value, its quality and its performance.

After a truly side by side comparison, you'll be convinced that its value, quality and features make it a truly outstanding value.

Why not visit your dealer today? If no dealer is available order direct from MFJ.

MFJ-961 1.5 KW VERSA TUNER III has balun, six position antenna switch. Matches coax, balanced line, random wire, from 1.8 to 30 MHz.



6 position antenna switch lets you select 2 coax lines thru tuner or direct, or random wire and balanced line.

\$139⁹⁵

1.5 KW PEP

The MFJ-961 1.5 KW Versa Tuner III gives you a flexible six position antenna switch. It lets you select 2 coax lines thru tuner or direct, or random wire and balanced line.

Run 1.5 KW PEP. Match any feedline from 1.8 to 30 MHz: coax, balanced line, random wire.

Gives maximum power transfer. Harmonic attenuation reduces TVI, out of band emissions.

Black all metal cabinet. Black front panel has reverse lettering. Flip down wire stand tilts tuner. 5x14x14 inches.

Encapsulated 4:1 ferrite balun. 500 pf, 6000 volt capacitors, 12 position inductor, ceramic switches. SO 239s, ceramic feedthrus. One year limited warranty.

Every single unit is tested for performance and

inspected for quality. Solid American construction, quality components.

For your nearest MFJ dealer, call toll-free 800-647-1800. Visit your dealer and compare. You'll find real value.

Why not see the NEW MFJ-961 1.5 KW Versa Tuner III at your dealer's today? If no dealer is available order direct from MFJ.

FOR YOUR NEAREST DEALER OR FOR ORDERS

CALL TOLL-FREE 800-647-1800

Order any product from MFJ and try it. If not delighted, return within 30 days for a prompt refund (less shipping).

Order today. Money back if not delighted. One year limited warranty. Add \$8.00 shipping/handling.

For technical information, order/repair status, in Mississippi, outside continental USA, call 601-323-5869.

Order By Mail or Call TOLL FREE 800-647-1800 and Charge It On



MFJ ENTERPRISES, INC.

P. O. BOX 494

MISSISSIPPI STATE, MISSISSIPPI 39762

CUSHCRAFT IS THE HF MULTI- BAND ANTENNA COMPANY.

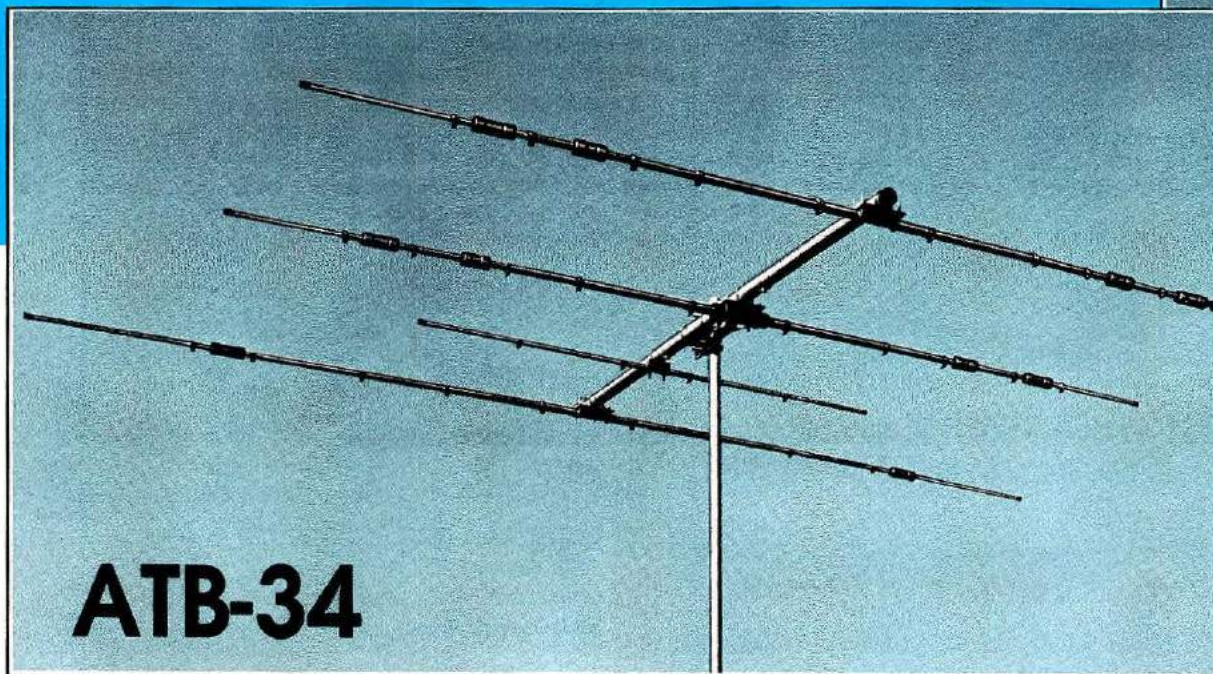

ATB-34

Punch through the pile-ups with an ATB-34. The only three band beam to give you real full size performance. Check ATB-34 element lengths, check the trap design and construction. Check the spacing and the specially developed balun. All of these features add up to the no compromise performance that you expect from Cushcraft.

SPECIFICATIONS

Gain	7.5dBd
F/B Ratio Avg	24dB
3dB Beam Width	62°
Nominal Impedance	50 ohm
Power Handling	2000 Watts PEP
Boom Length	18'
Longest Element	32' 8"
Turning Radius	18' 9"
Wind Area	5.4 Ft ²
Weight	42 lbs
Maximum Mast O.D.	2.5"

Cushcraft vertical antennas are designed to meet the exacting demands of your amateur radio station. They give top performance in easy to use packages. They can be installed at ground level or roof top.

Durability is guaranteed with double wall seamless aluminum base sections and fiberglass high Q traps. If you are interested in local contacts or long path DX communications, a Cushcraft vertical antenna is your best choice.

ATV-3

10-15-20 Meters
Height 13.8' (4.2mtrs.)

ATV-4

10-15-20-40 Meters
Height 19.4' (5.9mtrs.)

ATV-5

10-15-20-40-80 Meters
Height 24.4' (7.4mtrs.)

ALL MODELS

Power Handling 2000 Watts, Nominal Impedance 50 ohms, Maximum Mast Size 2" O.D., Termination: accepts PL-259

UPS SHIPPABLE



cushcraft
CORPORATION

THE ANTENNA COMPANY

IN STOCK WITH DEALERS WORLDWIDE P.O. BOX 4680 • MANCHESTER, NH 03108

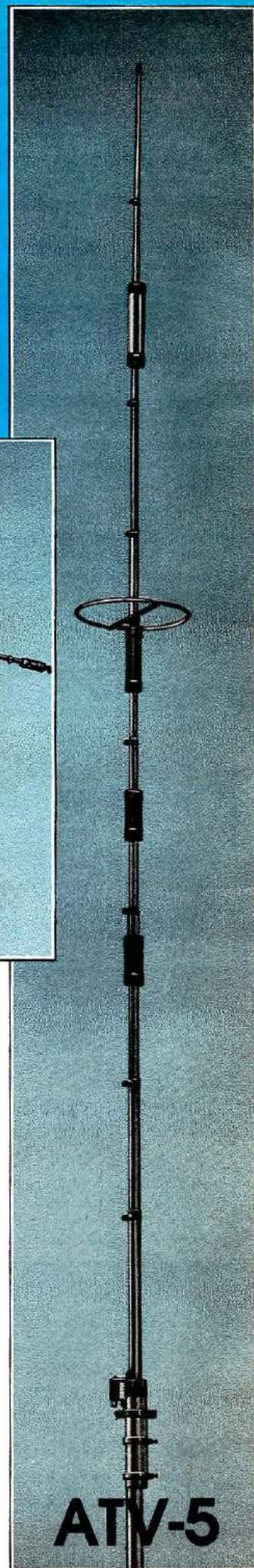

ATV-5

June, 1979
Volume 3, Number 6

T.H. Tenney, Jr., W1NLB
Publisher
James R. Fisk, W1HR
Editor-in-Chief

Editorial Staff

Thomas F. McMullen, Jr., W1SL
Managing Editor
Patricia A. Hawes, WA1WPM
Executive Editor
Martin Hanft, WB1CHQ
Administrative Editor
Charles J. Carroll, K1XX
Joseph J. Schroeder, W9JUV
Alfred Wilson, W6NIF
Assistant Editors

Publishing Staff

J. Craig Clark, Jr., N1ACH
Assistant Publisher
Fred D. Moller, Jr., WA1USO
Advertising Manager
James H. Gray, W1XU
Assistant Advertising Manager
James R. Wales
Art Director
Susan Shorrock
Circulation Manager

Copyright 1979 by Communications
Technology, Inc. Title registered
at U.S. Patent Office

Microfilm copies
are available from
University Microfilms, International
Ann Arbor, Michigan 48103

Cassette tapes of selected articles
from *Ham Radio Horizons* are available to
the blind and physically handicapped
from Recorded Periodicals
919 Walnut Street, 8th Floor
Philadelphia, Pennsylvania 19107

Ham Radio Horizons
is published monthly by
Communications Technology, Inc
Greenville, New Hampshire 03048
Telephone 603-878-1441
ISSN 0147-8818

HAM RADIO HORIZONS

CONTENTS

Hardware for Your Homebuilt Beams	12
Thomas F. McMullen, W1SL	
The Beast of Seven Trails West	20
Troy Y. Weidenheimer, W0ROF	
A Very Short Antenna	24
Douglas A. Blakeslee, N1RM	
Antenna Switching by Remote Control	32
David R. Malley, K1NYK	
Vacation Memories, Logbook Style	36
Julian N. Jablin, W9IWI	
That Delta Loop Again	42
Harry Leeming, G3LLL	
An Early Wireless Station	50
Alan S. Douglas	
Activities Calendar	76
Ad Check	78
Ad Scan	73
Advertiser's Index	78
DX Forecaster	74
Focus and Comment	8
Horizons Locator	70
Newsline	11
Postbox	58
Propagation Chart	75
This Month's Horizons	2
The View From Here	6

THE VIEW FROM HERE



When the band conditions are hot, as they have been for the past few months, in the late afternoon and evening you'll probably hear me prowling around the low end of the bands, looking for new countries for my DXCC. When conditions are just so-so, no doubt you'll hear me working one of the WAS or county-hunters' nets, but when a solar flare or some other disturbance completely destroys propagation, I usually spend my time in the shop working on one of the many projects I never seem to have time to finish.

More often than not when I'm in the shop I turn on the stereo and listen to some relaxing music, but once in awhile I flick on the receiver and tune around the upper end of 75 meters for an interesting round table — I can invariably find an interesting conversation, whether it's about the pros and cons of nuclear power, the fine fishing in the Colorado Rockies, or a technical discussion on the merits of quads versus Yagis. Whatever my mood, there's always something on 75 that piques my curiosity, and occasionally, something that starts the old adrenalin flowing.

Not too long ago, for example, two characters with two-letter calls were holding forth on the low end of 75 phone just inside the Extra class segment. The technical topic of the evening was transmission lines, and to hear these guys talk, they were the *original* experts. In reality all they had to offer was a barge full of baloney. Now I'll readily admit that, of all the subjects in Amateur Radio, transmission lines are among the most difficult to understand, but that isn't a license to run off at the mouth. And to be perfectly blunt, some amateur publications suffer from the same foot-in-mouth disease when it comes to transmission lines and antennas.

I don't know where all the feedline myths started, but I suspect it had something to do with the do-it-yourself SWR bridges which first became popular back in the early 1950s. Up until then most amateurs didn't even know about standing waves, and if they did, they didn't seem to care. SWR bridges soon caught on, however, and it wasn't too long before these handy little gadgets were more popular than peanuts at a beer party. One wag even suggested that the Q-signal QSW be used with a scale of 1 to 10 to report your latest SWR reading as you moved around the band; fortunately nobody took the idea very seriously.

Some amateurs got interested enough in the subject of standing-wave ratios to dig into the books, but when they discovered that SWR is a result of power reflected from a mismatched antenna, it only served to reinforce the myth. If a mismatched antenna causes power to be reflected back down the line, they reasoned, this power obviously wasn't radiated by the antenna. Some even suggested that the reflected power got back into the transmitter tank circuit and was dissipated in heat; others apparently thought that reflected power was lost forever to some great SWR heaven in the sky. A few well-informed amateurs tried to nip these absurdities in the bud, but it was hopeless — the disease spread faster than the cure.

The whole subject of transmission lines is much too complex to be covered in this short space, but it's time to bury some of the myths. First of all, reflected power is not lost nor does it heat up the tank circuit of your transmitter. Secondly, if your feedline has low loss, as is usually the case on 80 through 10 meters, increased loss due to SWR is so small you can forget about it. Since a 10:1 SWR on 100 feet of RG-8/U at 4.0 MHz increases loss by *less than 1 dB*, don't worry about the fact that SWR rises above 2:1 at the band edges — the station at the other end won't be able to tell the difference. If your transmitter doesn't like to load into a mismatch greater than 2:1, buy or build an antenna tuner and save yourself a lot of grief by forgetting the SWR on the line to the antenna if it's within reasonable limits, say 10:1. And finally, if you don't understand transmission lines and SWR, don't make wild statements before you have your facts straight.

Jim Fisk, W1HR
editor-in-chief

Imagine All The Places You Can Tuck ICOM's Remotable IC-280. (Think small.)

The **IC-280** 2 meter mobile comes as one radio to be mounted in the normal manner: but, as an option, the diminutive front one third of the radio detaches and mounts by its optional bracket, while the main body tucks neatly away out of sight. Now you can mount your 2 meter radio in pint-sized places that seemed far too cramped before.

Measuring only 2¼" h x 7" w x 3⅜" d, the bantam-sized microprocessor control head fits easily into the dash, console or glove box of even the most compact vehicle. Or if those places are already taken by the rest of your "mobile shack," the **IC-280** head squeezes into leftover niches under the dash, overhead, under the seat or even on the steering column.

But don't be misled by the petite size of this subdivided radio: the **IC-280** is jam packed with the latest state of the art engineering and convenience features. No scaled down technology here!

With the microprocessor in the detachable control head, your **IC-280** can store three frequencies of your choice plus the dial, which allows you to select from four frequencies with the front panel switch without taking your eyes off the road. These frequencies are retained in the **IC-280's** memory for as long as power is applied to the radio, even when power is turned off at the front panel switch. And if power is completely removed from the radio the ±600 KHz splits are still maintained!

The **IC-280** works frequencies in excess of the 2 meter band with ICOM's outstanding single-knob tuning, so you can listen around the entire band without fooling with three tuning knobs. With steps of 15 KC or 5 KC, the **IC-280** puts rapid and easy frequency change at your single fingertip and instantly displays bright, easy to read LED's.

- Available Options:**
- Touch Tone pad/microphone combination, which fits the mic plug on the radio face with absolutely no modification
(Fits all ICOM 4-pin mic radios.)
 - 15' unassembled cable kit for long distance remote mounting of the detachable control head



IC-280
2 meter FM, 4+ MHz
Mobile Transceiver

If you are a newly licensed novice, send for ICOM's catalog and discount purchase coupon. Mail your name, call sign and date of license to your ICOM distributor (see the bottom of this ad).

All ICOM radios significantly exceed FCC regulations limiting spurious emissions.

Specifications subject to change without notice.

IC-280 Specifications: □ Frequency Coverage: 143.90—148.11 MHz □ Operating Conditions: Temperature: -10°C to 60°C (14°F to 140°F). Duty Factor: continuous □ Frequency Stability: ±1.5 KHz □ Modulation Type: FM (F3) □ Antenna Impedance: 50 ohms unbalanced □ Power Requirement: DC 13.8V ±15% (negative ground) □ Current Drain: Transmitting: 2.5A Hi (10W), 1.2A Lo (1W), Receiving: 0.630A at max audio output, 0.450 at SQL ON with no signal □ Size: 58mm(h) x 156mm(w) x 228mm(d) □ Weight: approx. 2.2 Kg □ Power Output: 10W Hi, 1W Lo □ Modulation System: Phase □ Max. Frequency Deviation: ±5 KHz □ Spurious Output: more than 60 dB below carrier □ Microphone Impedance: 600 ohms dynamic or electret condenser type, such as the SM-2 □ Receiving System: Double superheterodyne □ Intermediate Frequency: 1st: 10.695 MHz, 2nd: 455 KHz □ Sensitivity: 1 uv at S+N/N at 30 dB or better, Noise suppression sensitivity 20 dB, 0.6 uv or less □ Selectivity: less than ±7.5 KHz at -6 dB, less than ±15 KHz at -60 dB □ Audio Output: More than 1.5W □ Audio Output Impedance: 8 ohms

HF/VHF/UHF AMATEUR AND MARINE COMMUNICATION EQUIPMENT

DISTRIBUTED BY:



ICOM

ICOM WEST, INC.
Suite 3
13256 Northrup Way
Bellevue, Wash. 98005
(206) 747-9020

ICOM EAST, INC.
Suite 307
3331 Towerwood Drive
Dallas, Texas 75234
(214) 620-2760

ICOM CANADA
7087 Victoria Drive
Vancouver B.C. V5P 3Y9
Canada
(604) 321-1833



FOCUS & COMMENT

I've just noticed a couple of sure signs that Spring has arrived — the latest list of flea-markets and auctions has every weekend for the next four months crammed full of events, and, this is our annual antenna issue of *Ham Radio Horizons*.

If your antenna survived the winter, you were either very fortunate, lived in a very mild climate, or did a well-planned job of building in the first place. Parts of the country that never before had more than a few chilly days suddenly got clobbered with ice storms and winds — sure death to large arrays of most kinds, especially quad antennas. However, as the weather warms, and the thought of those terrific openings on the higher bands invigorates Amateurs everywhere, I'm sure the antennas will go back up, perhaps bigger and better than ever.

Now, to a more serious note. There's a slow, creeping threat to our antennas and stations that will bear watching, or, perhaps a better way of expressing it is to say, we should take an active, informed, and aggressive stance against it. The threat is easy to identify but difficult to name, and the effects are likely to be longer-lived than whatever damage a winter storm can do. Simply stated, it is the threat posed by many well-meaning groups of people who see electromagnetic radiation of any type to be a threat to the health and well-being of you and me and them.

A case in point: Senate Bill 423, in Oregon. It is a bill that proposes to sharply restrict all electromagnetic emissions in residential areas. (Since most hams live in residential areas, that hits all of us.) The bill is practically all-encompassing, even down to naming electric power lines and transformers, as well as TV and Radio transmissions, as possible dangers to man and beast.

Another case in point: a few years ago, largely as a result of some *industrial* accidents wherein people suffered rf burns from high-powered uhf transmitters, Radio Amateurs (and all users of radio equipment) in Texas faced some bills in the legislature which would severely restrict power output from their transmitters — on any frequency.

I'm not going to try to argue about the extent of the danger, or even if any such danger exists or does not exist. In truth, nobody *really* knows the whole story about radio waves and their effects. Radio has not been around long enough to assess its danger to several generations of people living in fields of electromagnetism. Certainly, a rat or gerbil, placed in a restricted environment and subjected to strong radio fields, is not truly representative of real life; neither is a technician unwary enough to be working on a multikilowatt uhf transmitter with no shields in place! Animals, and, I suspect, humans too, usually sense when something is bothering them and take steps to get away from the source of irritation. If the source of irritation is a probe or antenna only a few centimeters from the captive animal, the fact that he cannot get away from it could be as emotionally disturbing as the radiation itself. You or I or your neighbor would feel just as disturbed if we had to spend our lives a few feet from the business end of a 10 meter beam, with the doors locked!

Fortunately, the bulk of radiation is directly in front of a beam antenna, which keeps it far above the usual habitat of people (another good argument against *tower* restrictions). As to incidental radiation — it is at a very low level (or should be, if your antenna is working right), and there is just no evidence to prove (or disprove) that such low-level energy has any effect on human behavior.

There is, of course, the possibility that scientific studies will eventually reveal harmful effects from low-level electromagnetic radiation, but such studies are not done overnight. If so, and we have to meet some new standards of safe radiation levels, so be it. But, let's make sure the restrictions are the result of scientific studies, not the aftermath of uninformed hysteria fed by someone with an axe to grind because he sees funny bars and sparklies on his TV screen, or because he always feels grumpy in the morning.

Incidentally, we hams are not alone in facing threats to our hobby. Almost any hobby group or special interest group has another special interest group trying to shoot them down; that's one of the prices you pay for living in a free society.

As has been said over and over, the price of freedom is eternal vigilance. I'll modify that to read: be vigilant, be well-informed, be rational, and be involved.

Thomas McMullen, W1SL
Managing Editor

NOW YOU CAN HAVE BOTH

HIGH QUALITY & LOW COST!



The DS2000 KSR FROM HAL

HAL design experience now makes it possible to offer you an efficient, reliable, and cost effective terminal for your RTTY or CW station. Investigate the new DS2000 KSR from the people who KNOW HOW to build RTTY and CW equipment. See how you can get great performance and save money too!

- Integrated keyboard and video generator
- 72 character line
- 24 line display
- 2 programmable "Here Is" messages
- Automatic carriage return and line feed
- QBF and RY test messages
- Word mode operation, full screen buffering
- All 5 standard Baudot speeds
- 110 and 300 baud ASCII
- CW identification at the touch of a key
- Morse code transmit
- Morse code receive (optional) self tracking speeds from 1-175 wpm on a separate plug-in circuit board (Available June, 1979)
- All in a convenient, small cabinet (14.1" x 9.25" x 4.35")

Price: \$449.00

Optional Morse Receive Board: \$149.00

Optional 9" monitor: \$150.00

BIG PERFORMANCE SMALL SIZE. . . SMALL PRICE

If you're looking for an RTTY demodulator with great performance on both the HF and VHF bands, take a look at the ST-5000 from HAL. The use of active filters with no phase-lock loop or 'single-tone' short-cuts ensure the kind of performance you expect. Full features in an attractive and conveniently small package make this demodulator a value that's hard to beat!

- Hard limiting front end
- Active discriminator
- Active detector
- Wide and Narrow shift (850hz and 170hz)
- Normal and Reverse sense
- Autostart
- Self-contained high voltage loop supply
- RS-232C voltage output (direct FSK)
- Audio tone keyer (AFSK)
- Provision for external tuning scope
- Attractive, small cabinet (2.75" H x 8" D x 12" W)
- Fully assembled and tested

Price: \$225.00

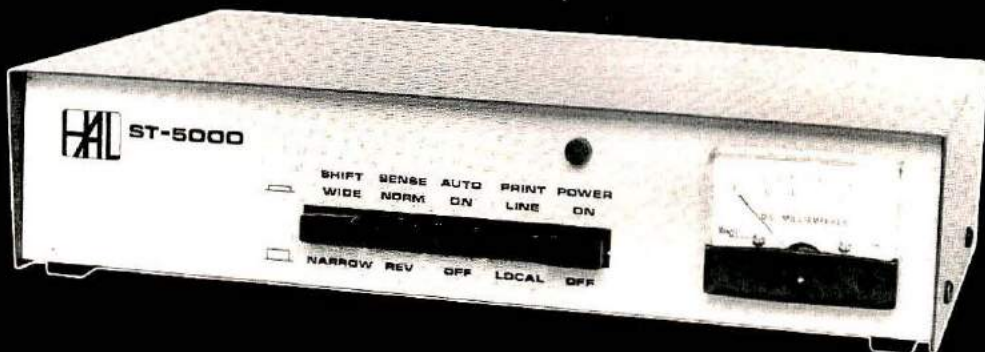

For more information call or write us at:



HAL COMMUNICATIONS CORP.

P.O. Box 365

Urbana, IL 61801

Phone: 217-367-7373

In Europe contact:

Richter & Co.; Hannover

I.E.C. Interelco; Bissone

SYSTEM THREE

WILSON'S NEWEST TRIBANDER FOR 20, 15 and 10 METERS

NEW!
BIG PERFORMANCE

\$19995
LIST
The Best Value
in Amateur Antennas
on the Market Today!
BIG VALUE

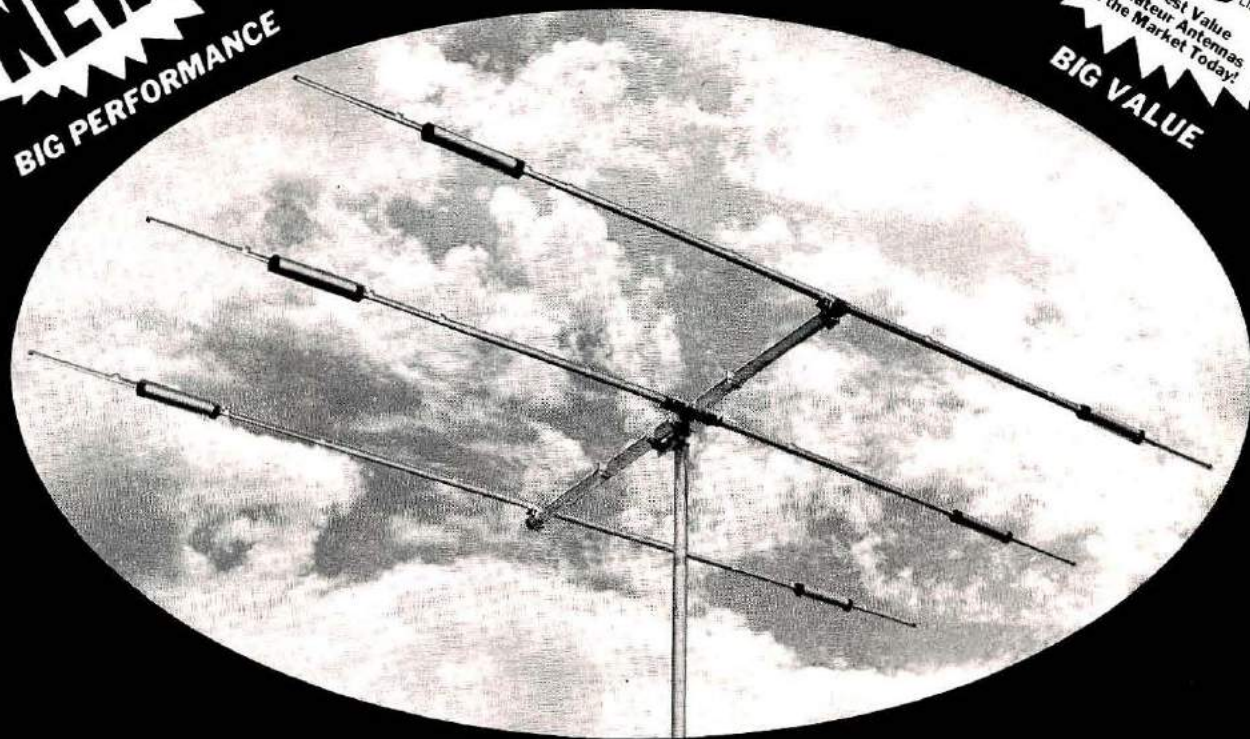

Capable of handling 2,000 watts, the "SYSTEM THREE" is the newest tri-bander available to the amateur.

Designed and produced by one of the world's largest antenna manufacturers, the traditional quality of workmanship and materials continues on with the "SYSTEM THREE".

The special heavy-duty vise-like extruded aluminum clamps on the reflector and director are a key point in the design of strength and durability.

Superior clamping power is obtained with the use of a rugged 1/4" thick aluminum plate for boom to mast mounting.

The use of large diameter High-Q Traps in the "SYSTEM THREE" makes it a high performing tri-bander with a very economical price.

A complete step-by-step illustrated instruction manual guides you to easy assembly and the lightweight antenna makes installation of the "SYSTEM THREE" quick and simple.

ACTUAL SWR CURVES

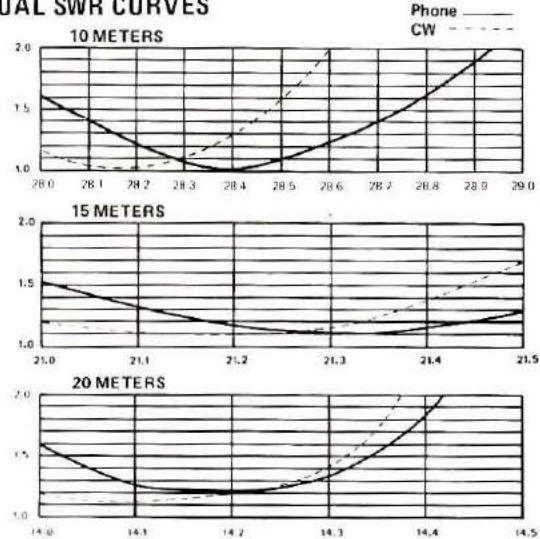

SPECIFICATIONS

Band MHz	14-21-28
Maximum power input	Legal limit
Gain (dbd)	8 db
VSWR at resonance	1.3:1
Impedance	50 ohms
F/B ratio	20 db
Boom (O.D. x length)	2" x 14'4"
No. elements	3
Longest element	27'4"
Turning radius	15'9"
Maximum mast diameter	2" O.D.
Surface area	5.7 sq. ft.
Wind loading at 80 mph	114 lbs.
Assembled weight (approx.)	37 lbs.
Shipping weight (approx.)	42 lbs.
Direct 52 ohm feed or balun maximum wind survival	100 mph

Prices and specifications subject to change without notice.



Consumer Products Division

Wilson Electronics Corp.

4288 S. Polaris / P.O. Box 19000 / Las Vegas, NV 89119 / (702) 739-1931 / TELEX 684-522

NEWSLINE

"WHISKEY CLUB" AND "HF" operation cost a Baltimore Amateur his license in an FCC Administrative Law Judge's decision released in late March. In their well-prepared case, FCC engineers established that they'd monitored Tom Kaufman, WA3VWC, operating on various non-CB 27-MHz frequencies and, on one evening had even heard Kaufman on 11 meters as "7Whiskey353," and a few minutes later on 28.782 MHz as WA3VWC. They also recorded operation by him as "HF 8644" on various 27-MHz frequencies.

Kaufman Had Earlier Pleaded guilty to the criminal charge of operating his Amateur station on frequencies not assigned to the Amateur Service, and was fined \$50. He also forfeited the gear that had been confiscated when his home was raided. The gear had an estimated value of \$1270. In view of his youth and his cooperation with the FCC after his arrest, the judge revoked his station license but suspended his operator's license for only one year, after which he can reapply for a new station authorization.

TWO BILLS TO AMEND the Communications Act of 1934 rather than replace it have been introduced into the U.S. Senate. The majority bill, S-611, is sponsored by Senate Communications Sub-Committee Chairman Senator Hollings and Senators Cannon and Stevens. The other, S-622, was introduced by Senator Goldwater with Senators Schmidt and Pressler as co-sponsors. Both were offered in response to the House proposal to rewrite the Communications Act, but both propose amending the existing act rather than starting over as the House bill had. Neither of the two bills addresses the growing RFI issue, and Amateur Radio rates only passing mention. S-611 does propose permitting the FCC to issue an Amateur license good for ten years, and both would exempt non-commercial stations serving the public interest from any user fees.

Neither Bill, as introduced, goes into much detail, with the understanding that they'd be considerably expanded during the course of extensive public hearings.

431-433 MHZ WILL REMAIN "off-limits" to ATV repeaters, the FCC decided at its March 15 meeting. Responding to two Petitions for Reconsideration on Docket 21033, the Commissioners noted that protection for weak signal and satellite operation was appropriate, but ATV repeater operators would always have the option of requesting a waiver. If the operator could establish a need for repeater operation in the protected segment, while showing his operation would not interfere with weak signal work there, such a request for waiver would be granted.

AMATEUR TRANSMISSIONS of emergency information cannot be rebroadcast by commercial broadcast stations, the Commissioners decided. Acting on a petition (RM-2830) filed by the National Association of Broadcasters, the Commissioners agreed to further consider whether CB emergency transmissions should be rebroadcast for public use.

A BRAND NEW EDITION of FCC's Amateur Radio rules, updated to January, 1979, has just gone on sale at the Government Printing Office. The revised Part 97 is stock number 004-000-00357-8, and price postpaid is \$1.40. Write Superintendent of Documents, Government Printing Office, Washington, D.C. 20402, or check at a GPO bookstore in larger cities.

"LEGAL ASPECTS OF PERSONAL COMMUNICATIONS" is the subject of a papers competition just announced by the Personal Communications Foundation. The competition, open to any law student in a recognized law school, will offer a \$500 first prize, \$250 for second place, and \$100 for third. Purpose of the competition is to stir interest in the field of personal communications law, and papers will be due October 1. For complete details on submissions, write Personal Communications Foundation, 10960 Wilshire Boulevard, Suite 1504, Los Angeles, California 90024.

FIELD DAY THIS YEAR (June 23-24) will find OSCAR 8 operating on both modes simultaneously, the ARRL has announced. Dual mode tests conducted during the satellite's birthday weekend showed the satellite to be capable of dual mode operation, and greater Field Day use of the satellite is expected as a result.

"UOSAT" — The University Of Surrey Satellite — will include a voice synthesizer to provide telemetry transmissions in plain English, include a 4,000 character datastore capability and a slow-scan TV camera for live cloud-cover pictures. Educators who've heard about the sophisticated bird are reported very enthused about its classroom possibilities.

AMSAT's 1979 Annual Meeting has been set for October 6 (a long weekend) at the Goddard Spaceflight Center.

CIGARETTE LIGHTER PLUGS can prove disastrous in some new cars, VE2BMQ warns in the VE2RM Bulletin. Some new autos with insulated dashes are wired in reverse, so check before plugging in.

A 29.705 MHZ "BEACON" for 10-meter FMers is offered by the Israeli Broadcasting Administration's recently introduced service on that frequency, operating weekdays 1400-1645Z in Yiddish and Russian. It's potent — over 100 kW ERP!



BEAM ANTENNA HINTS & HARDWARE

Putting some common materials to uncommon uses.

BY THOMAS McMULLEN, W1SL

You've decided to build a beam antenna, but you are so new at this Amateur Radio game that your hardware "junk box" is still empty, right? Or, you've read dozens of construction articles and picked the "Super-Signal-Snagger" as your dream antenna — then you find that the special clamps and brackets are made only by the author, who moved out of the country three years ago. At this point, the whole idea is beginning to become less and less attractive, and you're beginning to doubt that this "do-it-yourself" craze is all they say it is.

Well, before you grab the hammer and start making threatening motions toward your piggy bank, take the time to read a bit more. Perhaps I can show you a way to build your beam and save the bank for a rainy day (or a new rig).

Once you have gotten past the theory part of an antenna, all that remains is some hardware of various types, and you'd be surprised how much leeway there is for substitution and inventive-

ness here. An antenna can be divided into just a few parts — conductors, insulators, supports, and nuts and bolts to hold it together. There are very few cases where you cannot make a well-thought-out substitution, and you will be able to find most of what you need at your nearby hardware, automotive, and home-supply stores. Let's take a look at some of the possibilities.

Elements

These are the active parts of an antenna, and can be classified as conductors. There are several ways to make elements, and the most popular is to use aluminum tubing of various sizes. The ideal system is to find one size of tubing that fits inside another. The problem comes when you try to find a size that fits loosely enough that one will slide easily into the other, but not so loosely that it requires several pounds of hardware to keep the assembly from rattling in the breeze.

There are many variables to watch for when you start shopping for aluminum tubing, so plan to do a bit of searching before you find the right combination. There are different wall thicknesses, different hardnesses, different lengths, and even different tolerances for a given size of tubing. **Table 1** will give you an idea of what sizes will fit inside another, but note that it applies only to certain wall thicknesses. The important thing to watch for is that the smaller tube will slide smoothly inside the larger one, without the use of undue force. A very tight fit will jam, usually before you have enough overlap for support, and you'll have to resort to the hacksaw to get it apart again.

One of the easiest ways to join two pieces of tubing is to split the end of the larger one with a hacksaw — make a cut which is equal in length to approximately two times the diameter of the tubing. Then,

slide the smaller tube inside the larger, and clamp the two together with a hose clamp. There's no need to make a lot of cuts in the outer tubing; too many will weaken it beyond usefulness. In most cases, one pass with the saw, cutting through both walls, will do very well. There is seldom any need for more than two cuts (four slits) at the most. Hint for easier assembly: When you make the slits with a hacksaw, don't place the tubing in a vise and wind it up tight — you'll crimp it enough that the inside piece will jam. Hand-pressure to hold the tubing against a V-notch in a bench, or against some other support, should be used, and cut slowly and evenly with a fine-tooth hacksaw blade. Remove any inside burrs before assembly — you have only a few thousandths of an inch clearance in properly telescoping sizes.

If you have no luck finding tubing that fits properly for a neat telescoping assembly, you can still make the element you need by simply placing a bushing between the sizes, see **Fig. 1**.

The thickness of the bushing will depend upon how big the gap is, of course. I've often used a split piece of aluminum tubing as a go-between — this is one of the reasons I never throw out scrap ends of tubing, especially those with thin walls. Sheet-metal strips can be rolled around the inner piece to form a good sleeve or shim. Just remember that you will be taking up twice the thickness of the material — a piece 1.5 mm (1/16 inch) thick will fill a gap of 3 mm (1/8 inch) between tubing sizes.

As an alternative to using hose clamps, you can run three or four sheet-metal screws, or even pop-rivets, through the walls to fasten the joint together, as in **Fig. 1**.

Table 1. These sizes of aluminum tubing are stocked by many warehouses in the United States and Canada. Note that each size listed will telescope into the next size, assuming that each has a wall thickness of 0.058 inch, which leaves a clearance of 0.009 inch. Don't try to work with less clearance or the pieces will jam. Because of its strength and ease of working, 6061-T6 (61S-T6) round aluminum tubing is recommended. It usually comes in 12-foot lengths, and is sold by the pound. Aluminum in your local do-it-yourself hardware store may or may not have these dimensions — check the fit before you buy.

Outside Diameter, Inches	Wall Thickness	Fits Into	Weight in pounds, 12-foot length
1/4 (.250)	.058	3/8	.492
3/8 (.375)	.058	1/2	.816
1/2 (.500)	.058	5/8	1.040
5/8 (.625)	.058	3/4	1.452
3/4 (.750)	.058	7/8	1.776
7/8 (.825)	.058	1	2.100
1 (1.00)	.058	1 1/8	2.424
1 1/8 (1.125)	.058	1 1/4	2.736
1 1/4 (1.250)	.058	1 3/8	3.072
1 3/8 (1.375)	.058	1 1/2	3.384
1 1/2 (1.500)	.058	1 5/8	3.708
1 5/8 (1.625)	.058	1 3/4	4.032
1 3/4 (1.750)	.058	1 7/8	4.356
1 7/8 (1.825)	.058	2*	4.668
2 (2.00)	.049	2 1/4**	4.200
2 1/4 (2.25)	.083		7.920

* 0.049 wall thickness

** 0.083 wall thickness

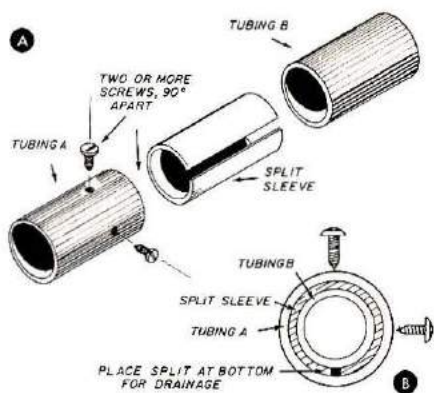

Fig. 1. A method of joining two pieces of tubing that do not fit closely enough for good telescoping action is to place a split sleeve between them, **A**. The assembly can be fastened together by means of two or more sheet-metal screws, **B**. Place the screws at right angles to each other for maximum holding effect.

Insulation

Beam antennas of the early days were generally made of wire, supported on a wooden or metal framework. As aluminum tubing became available, and less expensive, the framework persisted for a time, but the elements still were supported on ceramic pillar insulators. That is a good method of building beams, but large ceramic insulators are becoming increasingly difficult to find.

Fortunately for us, the center of a half-wave element is the "coldest," as far as rf voltage is concerned, which means that mounting it to another piece of metal at that point should have no effect on its operation. This is generally true, and the only elements that need be isolated from the metal support are those that are "fed," or driven, with energy from the coaxial cable. There are exceptions here: a noninsulated element can be fed by means of a gamma match, but not all antenna designs you'll read about make use of that system.

Equally fortunate is the fact that where the voltage is so low, we can use almost any insulation that will not absorb moisture. Many early beam antennas and television DX

arrays (in the 1950s) used hard-rubber blocks as insulators. Bakelite was common, as was a very hard substance called Micalox. These are still good insulators, if you can find them. A more readily available material, however, is PVC tubing or pipe. You can obtain enough to insulate a lifetime supply of beams by going to your nearby plumber and asking him for some short pieces which were cut off when they were "plumbing" a new house or apartment.

Simply split a short length of plastic pipe and wrap it around the element you want to insulate, place it under the U-bolts, and you have an insulated element! What could be easier?

Strengthening

Just as a rope is weakened by a knot, a piece of tubing becomes weakened where it joins another part of the antenna. Any stress or vibration has its most severe effect at the U-bolt or clamp that holds an element in place, at the boom-to-

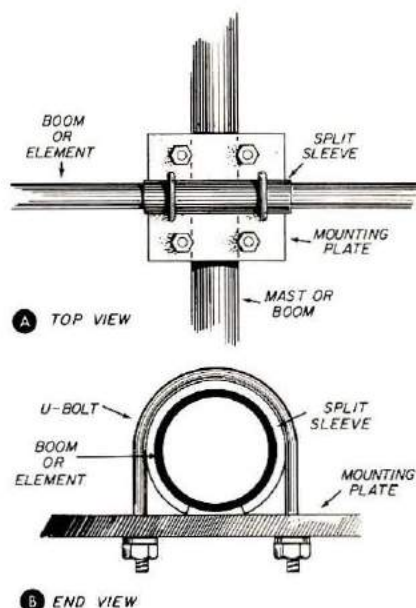

Fig. 2. U-bolts will crush tubing when tightened. A cure for that is to place a split sleeve over the tube to reinforce it. Note the thick aluminum mounting plate used to keep two pieces of tubing at right angles to each other — a good source of material for these plates is scrap aluminum panels of 3 to 6 mm (1/8 to 1/4 inch).

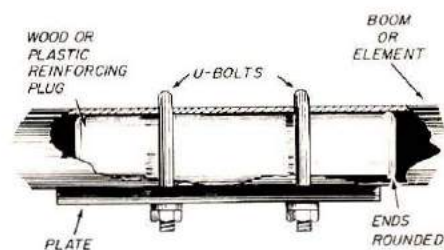

Fig. 3. You can also strengthen a boom or element by placing a wood or plastic plug inside it. The plug should be a sliding fit inside the tube, and long enough to extend beyond the U-bolts on both sides. Round the ends, or give them a slight taper to prevent metal fatigue at a sharp corner.

mast clamp, or wherever there is an abrupt change in size or thickness of the material. If you want your creation to stay in the air, you must take steps to relieve that stress.

A handy method of providing extra strength where U-bolts are used is to place a split sleeve on the outside of the element or boom, as shown in **Fig. 2**. The sleeve spreads the pressure of the clamp over a greater surface area than the contact points of the U-bolt alone, thus adding to your beam's strength and longevity.

In cases where it is not practical to place a sleeve on the outside, you can put a wooden dowel on the inside for much the same effect, **Fig. 3**. Hardwood dowels are best, but almost any snug-fitting piece of wood or plastic will be better than none at all (snug fitting but not tight — you'll have trouble forcing a tight plug to the midpoint of a long piece of tubing). Here's a tip — round the ends of the plug slightly, or even give the last inch or so a *slight* taper. This allows a gradual contact which will help dampen vibration. Make the plug long enough to extend 5 to 7 cm (2 to 3 inches) beyond the last clamp.

In areas subject to high winds or heavy ice accumulation in the winter, some builders have had good results by placing another piece of tubing, or even steel conduit, inside the main boom of their

beam. This keeps the clamps from crushing the boom, and provides added strength over a good portion of the boom's length. Here, again, it is important to round the ends of the interior pipe to allow any stress to dissipate without fracturing the tubing at a sharp edge.

The rf path

One very important thing to keep in mind when building any antenna is the path that the rf must take through the elements. It is not unusual to build a beam with elements made up of several pieces of tubing fastened together to make the right length. Each joint must be a good one, electrically and mechanically. They'll be just fine when new, and all the shiny surfaces fit together well. However, moisture and gases will corrode the metal, causing intermittent contact, or none at all. At best, this will cause noise in your receiver, create harmonics or other forms of interference when you transmit; at worst,

Here is an assortment of hardware you'll find handy when putting beam antennas together. It's easy to recognize the hose clamps, lower left, and they're available at almost any hardware, plumbing, or auto-parts store. The small U-bolts at upper left are hardware-store items. Two types of muffler clamps are shown here — use the type shown disassembled at the upper right. Note that the pressure plate is formed so that there are two edges to bear upon the tubing being clamped, instead of the single edge of the one near the center. The pair of U-bolts at the lower right are common TV-antenna installation hardware, available almost anywhere TV sets are sold and installed.

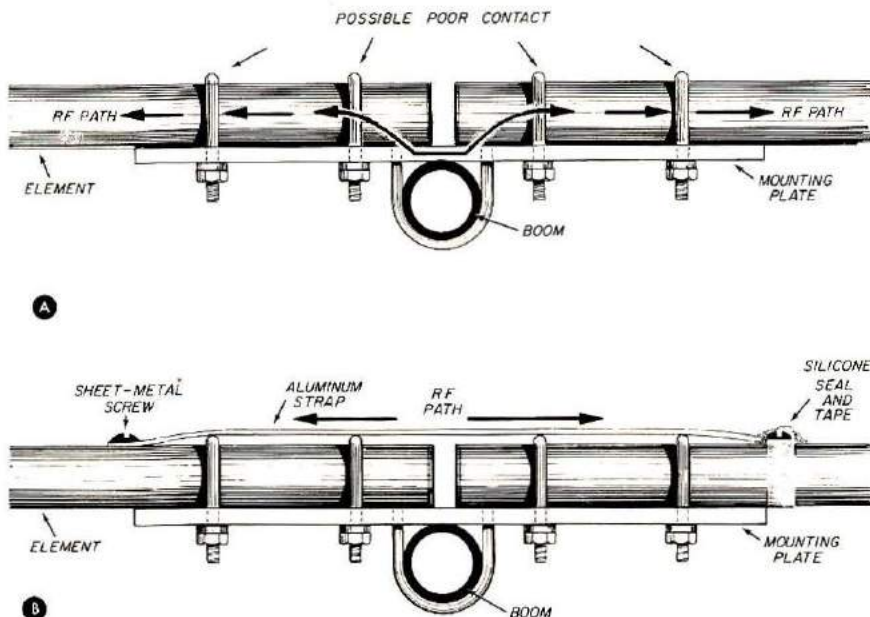

Fig. 4. Be sure that the rf path through the elements is as smooth and continuous as possible. An aluminum strap should be placed across any discontinuity, and any critical joints should be sealed and taped for weatherproofing.

it can cause the antenna to refuse to accept power at all.

The secret is to protect the rf path from the effects of moisture and gases. After your tub-

ing has been telescoped together, spray the joints with a clear sealant — there are several types available in pressure cans. In severe cases, you may need to apply a silicone caulking compound, tape over that, and then spray the entire area with acrylic lacquer.

One trouble spot that is often overlooked is the joint at the center of a long element — where two pieces of tubing meet at the boom, see Fig. 4. The usual method of construction here is to use four or more U-bolts to hold the tubing to the mounting plate. The rf path, in going from one end of the element to the other, must go through the U-bolts, into the plate, then through the other U-bolts to the other half of the element. The point at which the U-bolts bear on the element is not very large, and is one of the first places to corrode. This, too, can cause noise and poor operation. You can cure this problem by placing an aluminum strap across the whole assembly, thus providing a direct path for the rf. The strap can be fastened in place with sheet-metal screws, and the screw heads and strap ends

sealed with caulking compound and tape for weatherproofing.

Beam antenna elements that vibrate in the wind not only create noise than can be disturbing in the still of the night, but they also break. The stress of the vibration creates metal fatigue at the point where the element is connected to a heavier piece of metal (usually at the element-to-boom clamp), and this leads to a cracked or weakened element. It will usually break in a high wind just before (or during) a contest weekend, or when some hapless bird decides that your beam is the best place from which to survey his kingdom.

One very successful method of dampening vibration is to place a length of plastic rope inside the tubing. It doesn't have to be tight, just run it the full length and let it lie there. The rope's inertia will be "out of phase" with the vibration of the element, and it will tend to soak up energy, thus dampening the vibration. For small elements, the light, braided-plastic ropes of 3/16 to 1/4-inch size will do well; larger sizes will work for the larger-diameter elements, up to rope of 1/2-inch or so. Use the plastic stuff — braided cotton or natural fiber will soak up moisture and decay, causing the element to deteriorate from inside. Also, be sure the rope is small enough to freely flop around inside the tubing; the tendency to absorb energy when it moves in one direction, and meets the tubing moving in the other, is what makes it work.

Some constructors have reported good results by filling elements and booms with plastic "peanuts" such as those used for packing delicate equipment for shipment. Again, these must fill the element to the ends, but not be packed so tight that they cannot move and "jostle" around when the tubing vibrates. The "peanuts" can be kept inside by either crimping the ends of the elements or by placing a tight-fit-

ting plastic cap on the ends.

Putting it all together

Here's where you can really practice being ingenious, and devious. Any time that my travels take me to a different part of the country, I try to find a few minutes to check out the nearby hardware stores. You just never know when you'll find some clamp or gadget that will be "ideal" for putting together a new beam. The security agents at the X-ray counter at airports must hear some incredible stories, but none more "far-out" than my explanations for that assortment of weird clamps and stuff in my luggage. I've also developed a set of answers for the store clerk who wants to know if this stuff is for drinking-water

plumbing, waste-water, new construction, or old.

For instance, there is a marvelous assortment of pipe-hangers available at the better-equipped hardware stores and at most plumbing supply houses. Try several houses — everyone has his idea of how a pipe should be fastened in place, and the style and shape of hardware reflects these differences. One of my favorite types is shown in an accompanying photograph. These clamps can be used in many ways to fasten a variety of tubing sizes together. Hint: Take along a small sample of the element and boom tubing — try the clamps for fit, even if the clerk argues loudly that "it's not made for that use!"

Another favorite source of

Two pieces of tubing joined by clamping with a hose clamp, at top. Hint for added strength: don't cut a long piece of tubing just to allow it to protrude a short distance inside the outer one. The extra length inside will strengthen the assembly, and, if you ever need to change the element or boom size, you have plenty of material to work with. The plate with U-bolts, lower right, is a common way of joining a boom and mast. The plate can be made of a scrap aluminum panel or other material of 3 to 6 mm (1/8 to 1/4 inch) thickness. The block at lower left is a boom-to-mast casting salvaged from a defunct TV antenna. Just above it is a cast pipe-hanger clamp. They're available in many sizes, and with a variety of threaded holes for mounting.

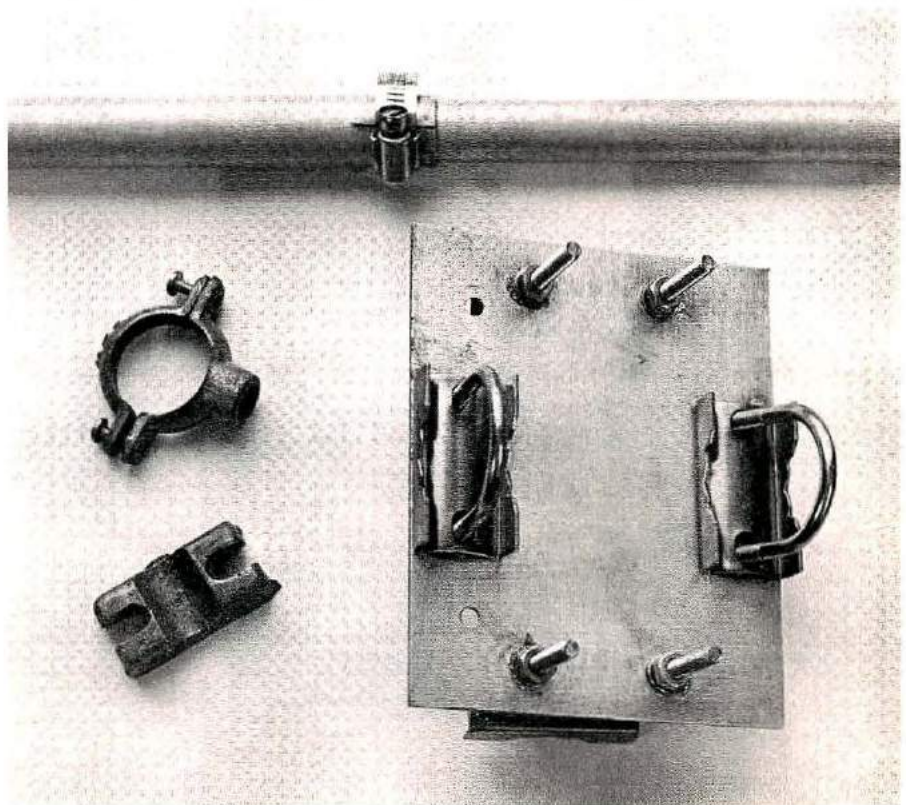

hardware is the automotive parts store. One of the photographs shows muffler clamps. They come in a wide range of sizes, so there again, take along a sample piece of tubing. The largest clamp I've seen so far is 10 cm (4 inches) inside diameter. (I'll never build a beam with a boom that size, but it's nice to know the hardware is available, just the same).

To use the clamps, you'll need a plate of some sort to act as a go-between. A square piece of aluminum will work fine for joining two large pieces of tubing, such as fastening the boom to the mast. A piece of aluminum angle stock, or a flat plate, makes it possible to mount elements to the boom by means of a muffler-clamp.

Most muffler clamps are plain, untreated steel, and they usually have a coating of oil when you buy them. The oil is messy when you are trying to build an antenna and will not stay there long in any case, so you might as well clean it off right away. This, however, leaves the clamp and its hardware very susceptible to rusting. The easy way to take care of that is to spray the clamp with some type of rust-preventative primer and paint. I've found that some of these work fairly well for a year or two, but eventually the moisture gets inside and does its dirty work. A better solution is to have the clamp and all its hardware (washers, pressure plate, nuts) plated. Many job shops will take a handful of clamps and run them through a cadmium-plating bath for a modest fee, and it's well worth it to have clamps that will last a while (and they look quite "professional" too).

Single-screw mounting

Elements that are comparatively light, such as those for use on the vhf bands, can be fastened to the boom in a much simpler manner than by

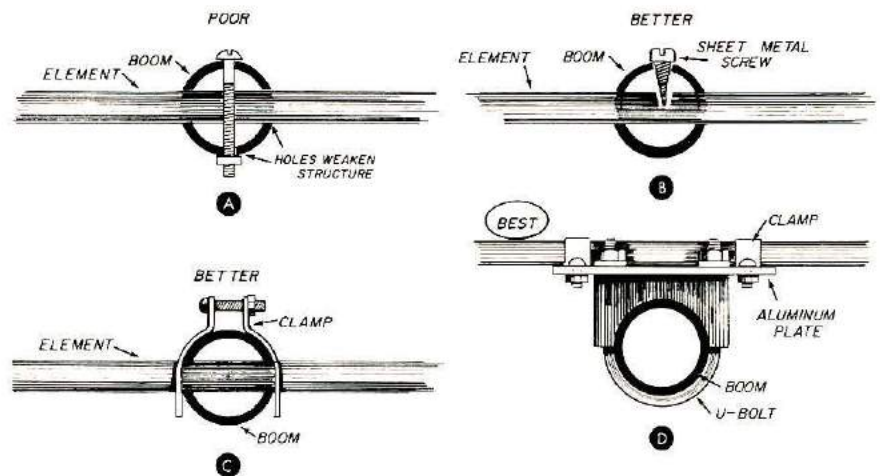

Fig. 5. There are many ways to mount elements to booms, and some are invitations to disaster, as in A. The multiple holes weaken the boom. The best system is in D, with no holes in the boom needed.

using U-bolts and plates. A long-time favorite of many builders is to drill a hole in the boom, then place a bolt or sheet-metal screw through both the element and boom to hold things in place. I always shudder when I see an otherwise well-designed antenna built that way. Any hole through the boom weakens it, and the larger the hole, the weaker the assembly will be. Drilling two holes at right angles at the same place on the boom is inviting disaster, see Fig. 5. I'm always looking for ways to avoid drilling holes in the boom.

One solution is the cast, split-ring clamp available from Kirk Electronics.* However they come in sizes to fit only a few boom diameters. They usually have a pilot-hole drilled which you can enlarge to fit several sizes of element, up to approximately 9.5 mm (3/8 inch).

My experimenting led me to develop my own version of a "split-ring" clamp, shown in the photograph. It is made from aluminum sheet, and you can make it fit almost any boom and element combination you want. An added benefit is that you can modify the design a bit

*Kirk Electronics, 75 Ferry Rd., Chester, Connecticut 06412.

and — presto! — you have a place to mount the coax connector, at no extra cost. I've used aluminum salvaged from old chassis, stuff found in the scrap yard, and strips left over from large sheets of aluminum that were being trimmed for another purpose. Thickness is not overly critical — it must be strong enough to hold the element yet thin enough that you can bend it back on itself around a 6.5-mm (1/4-inch) or larger bolt. The aluminum must be hard enough that the pressure of the bolt will not deform it, yet soft enough that it will not crack when you bend it. Try a scrap piece, bent around a bolt or rod, and look for cracks.

Bar stock

No, not the bottled kind — the solid-aluminum kind. Element-to-boom hardware made by drilling holes in bars of aluminum stock is rugged, looks great, and is not too expensive. However, if you're going to build more than an 8- or 10-element yagi, be prepared for a lot of drilling! Aluminum-supply houses have square and rectangular bars in stock, usually sold by the pound. Try to buy it with a larger order (include it with your tubing order, or with a friend's order) to keep the cost down. I limit my use of clamps made this way to booms of 12

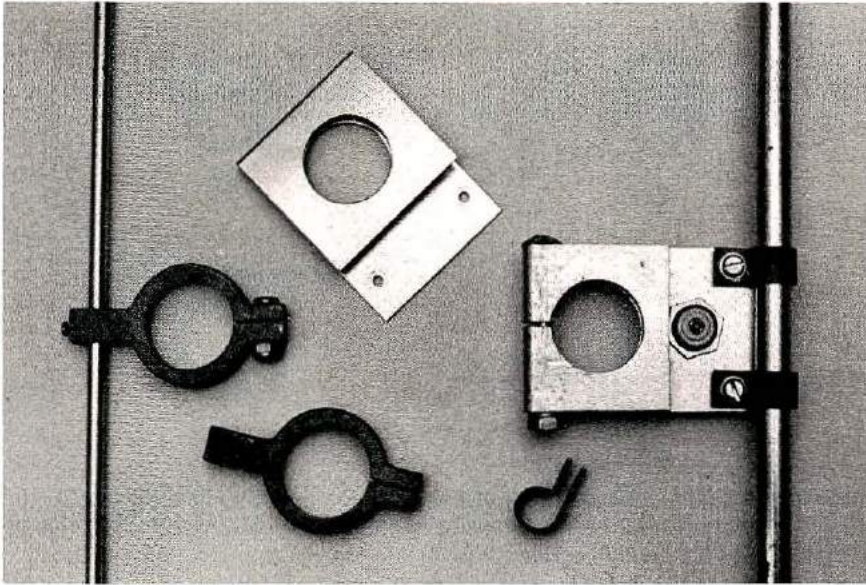

A commercially made clamp, left, by Kirk (see text for address). My home-made version (top center and right) is simply a piece of sheet aluminum with holes (made by a Greenlee chassis punch), folded back upon itself so the holes will align. The folded part is split with a hacksaw, and a bolt run through for tightening. The completed version at right was made a bit longer to allow room for a coaxial connector. Element is held in place by two clamps of strip aluminum, formed as shown just below the assembly. Holes in these boom clamps will fit standard 1-1/8 inch TV-mast tubing.

to 16 mm (1/2 or 5/8 inch) or less because of the difficulty in obtaining drills for larger sizes, and because the weight of the blocks adds appreciably to the weight of the beam. The bar should be just slightly larger than the boom diameter, because it is difficult to drill a smooth hole if the bit extends beyond the edge of the stock. **Caution!** Use good clamps to hold the stock in place on the drill table, and run large drills at a low speed. To make the clamps, simply drill a series of holes at right-angles to each other, one hole the size of the element, the other the size of the boom. Then, use a hacksaw to separate each "clamp" right across the middle of each hole, see photograph. The form-fitting walls of the "half-hole" will prevent the element and boom from being crushed when you tighten the single bolt through the whole assembly. I must admit, however, that the idea for this one came to me when I found some crude castings on an old TV antenna at the town dump. I didn't have a

means of making castings, but I did have a drill press — hence, my improved, but more costly, version.

An element and boom, center, joined by a block of aluminum shaped to fit the contour of both pieces of tubing. The block was made by drilling holes (at right angle to each other) in a piece of bar stock, then separating the pieces by a hacksaw, lower left. The castings at the lower right serve the same purpose, and were salvaged from a discarded antenna — as were the spacers and bolt just to their right. The two pieces in the upper right and left are also salvage from scrap antennas.

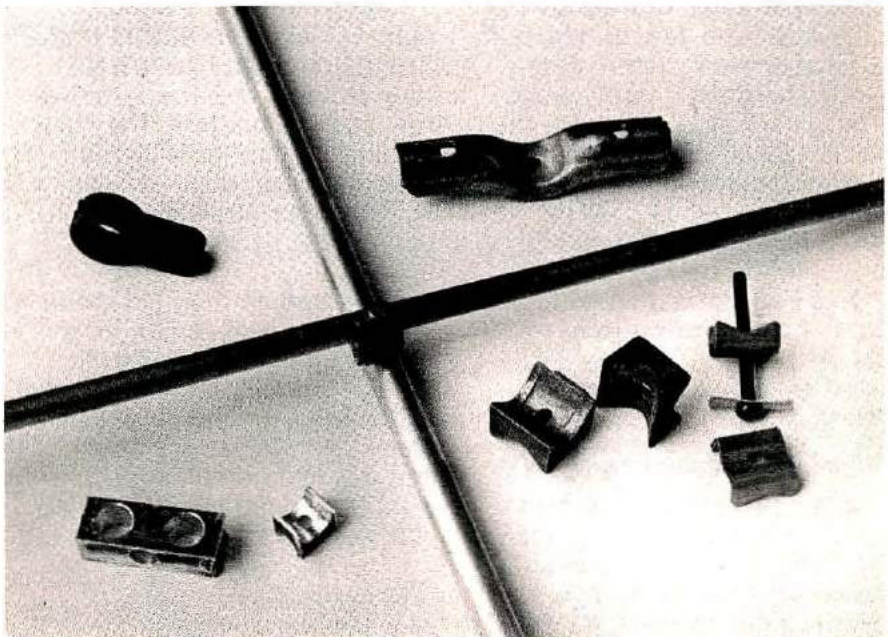

Another piece of element-mounting hardware which I often make, rather than buy, is a small clamp somewhat like the old-fashioned hose clamp with a tail on it, see photograph. It is simply a strip of aluminum with a hole drilled in each end, bent around the element, and the "tail" squeezed shut in a vise, or with pliers. A bolt can be passed through the hole to fasten the assembly to whatever support is necessary. The length of the strip, and the distance between the holes, should be such that there is still a small gap between the tabs after the bolt is tightened up, thus maintaining tension to hold the element in place.

Again, a scrap chassis is a good source of metal to make these clamps, and the aluminum must be soft enough to bend without cracking.

Salvage

If you truly aspire to be a hard-core antenna experimenter, never pass up a chance to collect scrap antennas. Cruise your neighborhood after

every severe windstorm in the summer, and after ice storms in the winter. Visit your town dump, if they'll let you pick it over (some towns are very fussy about this), or keep in touch with all your nearby TV sales and installation houses. A little friendly persuasion, a cigar, a can of soda or beer, will ensure that on your next visit there will be a pile of mangled aluminum tubing waiting for you. Most of the tubing will be worthless, and you can collect and sell it by the pound.

The real gravy is the hardware you can accumulate! Most element-to-boom hardware will be fastened in place by rivets, but a few minutes work with a sharp drill will remove those. I'll give you fair warning though — the number of any given type of clamp you have on hand will always be one less than you need to put together a pet beam. If you're going to make a 10-element Yagi, you'll have nine of one style clamp, and one each of a dozen others! That's one of the hidden laws that haunt antenna-building enthusiasts. That's also the reason I schemed and pondered until I found a way to duplicate the function, if not the appearance, of many pieces of hardware.

Wire elements

I've been talking about beam antenna elements made of aluminum tubing, but there's no reason to forget that you can make some very neat arrangements by using wire for the elements, as some *Horizons* articles have pointed out.^{1,2} The advantage of such an arrangement is low cost. The disadvantage is that you must provide a support for the wire, and providing a rugged support for a very large beam can be difficult. Such supportes are usually nonmetallic, which means that they are heavy, subject to moisture absorption, and break easily. Nonetheless, wire-element beams for the 20-

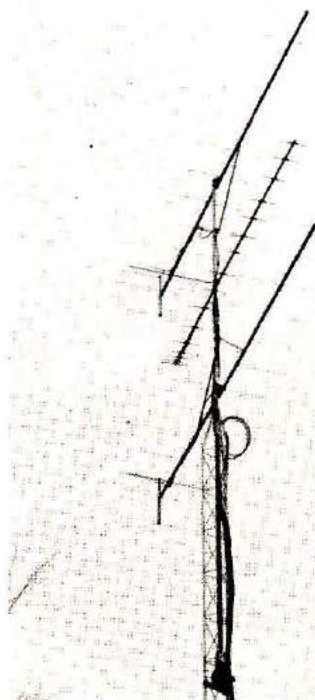

Antennas are fun to build, and you can take real pride in your work when they perform well and have a well-engineered appearance. This pair of home-made two-meter Yagis has done a great job for two years and withstood some severe ice and wind at my New Hampshire QTH. The small antenna in the center is for 432 MHz, and was made by KLM.

10-, and 6-meter bands are small and inexpensive enough to be worth considering, and if properly constructed, they will last many years.

Tower tip

In these days of small building-lots and crowded neighborhoods, hams often place a tower at the side of the house — either to keep it as far from the edge of the lot as possible, or to gain added support by fastening a bracket to the eaves of the house. This is fine, but towers tend to hum, creak, and thump in even the slightest of breezes, all of which can be very disturbing to a light sleeper. A friend (WA1NXP) found a way to quiet things down a bit. He obtained a pair of motor-mounts from a defunct Volkswagen and placed them between the tower legs and the eaves bracket. The rubber cushions tend to damp

out most of the noise, yet provide adequate support for the tower. It'll take some planning, and most likely some welding too, to fit whatever motor-mounts you have to your tower and bracket, but the improvement is well worthwhile.

Welding, brazing, soldering

Sooner or later some of you will see an advertisement for some "miracle" aluminum solder or an aluminum-welding process, and you'll look upon this as the answer to an antenna-builder's dream. I know, because it has happened to me — several times — and I hate to think of how much aluminum tubing I transformed into scrap each time a new product was advertised.

The stuff works, there's no denying that. However, there are two major drawbacks as far as an experimenter is concerned. First, it's permanent. If you want to change something, or replace a broken element, lots-of-luck. Second, the inevitable heating required to make a proper bond between an element and the boom will seriously weaken both of them. I once built a pair of two-meter Yagis, each element nicely "brazed" in place. It was a masterpiece, each element secure from weather-induced corrosion and sporting a smooth fillet of metal where it joined the boom. I was really proud of it until the first ice storm, which left it looking like the most mistreated umbrella in the world. The softened aluminum had all the strength of damp spaghetti. My conclusion is that I'll stick to nuts and bolts to build Amateur antennas.

References

1. John Tyskewicz, W1HXU, "Tri-band Wire Yagi Antenna," *Ham Radio Horizons*, December, 1977, page 26.
2. John Tyskewicz, W1HXU, "Simplex 3-Band Wire Beam," *Ham Radio Horizons*, November, 1978, page 56.

HRH

The BEAST of seven Trails West



They say a monster lives in the park behind our apartment complex. Invisible during the day, it looms up in the moonlight, swinging and swaying in the night wind. And its voice is an eerie metallic rattle. And they say that sometimes it puts funny lines on your TV screen. It's a creature with three great necks stretching skyward. And it's mine.

I remember the terrible day I arrived at Seven Trails West Apartments. One look at the "No Antenna" clause in the rental contract would engulf even a repeater jockey in waves of dismal depression. For me, a QRP_p (low, low power) DXer who relies on lots of antenna to make up for lack of power, it spelled doom . . . the certain end to all I cared about in life.

I became morose, quit eating. My eyes grew dull and my body temperature fell to the low sixties (not uncommon among DXers during sunspot

minima). For nearly a month nothing remained of my usual bountiful spirit but a pilot light flickering weakly. I'd gone dormant.

But, in the dark recesses of my inner mind, there was a flurry of activity. I sensed that soon the dilemma would surface.

On Thursday, July 24, while enjoying a quiet dinner with my family, my mind exploded. I sprang from my chair, eyes flaming. Wisely, my family found shelter in the kitchen and peered out at me through a crack in the door. In seconds I was in the hall closet attacking the man-sized stack of ham magazines.

"It's here . . . It's here SOMEPLACE," I screeched.

"W . . . W . . . what's there?" ventured my XYL.

"Article . . . invisible antennas . . . how to make 'em . . . AH . . . AH, I have it!"

Down the basement steps I bounded. Snatching up a huge roll of No. 28 magnet wire, I clutched it to my chest. My eyes flashed with devious intentions. "A micro-fine, completely invisible, all-band, end-fed long wire!" Muttering to myself, I quickly measured

the length of the basement room, drove tiny nails in opposing walls, then began spooling off wire. Skipping back and forth across the room with my wire, I might have been a great spider awkwardly weaving a web.

I rolled the measured wire back onto the spool, pounced up into the living room, and made for the glass patio door. Without caution, I threw back the curtains covering the door and immediately recoiled in terror. "Ohhhhhh," I moaned, like a vampire caught in the open at dawn. The light poured in. Starkly revealed, I stood clutching three hundred feet of wire and a dozen ceramic insulators. And there were the neighbors, barbecuing something dreadful, just beyond our patio. Had they seen me? And how could I explain what I was preparing to do? Fortunately, they were so engrossed in their smoky toil that they remained oblivious to my sudden appearance and equally sudden retreat. Shaken, I slumped into the old recliner and vowed patience till nightfall.

By 10:30 PM, only a faint sliver of moonlight slipped down through the clouds. The common grounds behind our apartment were suitably cloaked in darkness. In my black turtleneck and dress-suit pants, I was the epitome of stealth. With wires and insulators in hand, I slithered

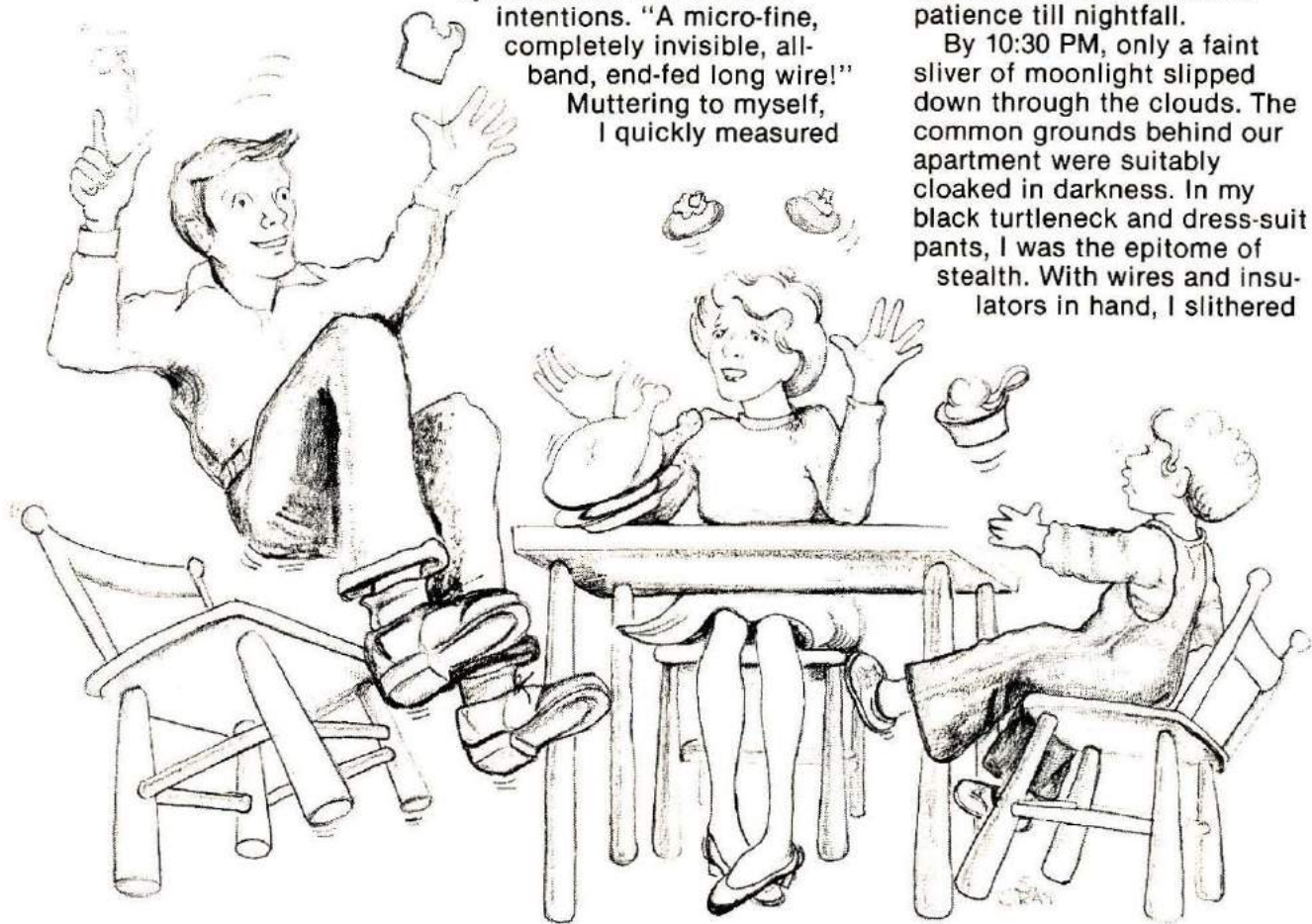

into the yard, crept along the side wall of the townhouse, knelt, and fed one end of the wire into our basement window. That left only 295 feet to string through the trees and buildings without being detected. My confidence dwindled.

A large, park-like area of common ground lay directly behind our townhouse. But fifty apartments which looked out on this setting sent an equal number of probing shafts of light out over my prospective antenna farm.

Like Red Ridinghood's wolf, I started out streaking from tree to tree. My heart pounded both in anticipation and trepidation. Clinging with one arm to the trunk of a towering cottonwood, I dug into my bulging pocket and withdrew the pair of C cells I had taped together to provide weight for my "throwing string." Cautiously backing into the tree's shadow, I began to swing the weighted string around my head, aiming for a branch high in the tree.

Round and round, faster and faster the weights whirred through the air and . . .

"TWANK!" At approximately Mach 4, the batteries parted company with the string and whizzed off on a flight path which I quickly calculated would pass directly through the great picture window of apartment No. 313.

SURPRISE! The window did not disintegrate. Instead, the batteries altered their course magically, and whanged against a massive, forty-foot-high downspout by the window. Instantly, one hundred glowing eyes glued themselves to the glass rectangles which looked out on my hiding place. Few things go "CLANK!" in the night at Seven Trails West. And that one had hit with the impact of a crazed condor.

Heart pounding, I pressed still closer to the tree and waited. As the last reverberations died in the downspout, the eyes drifted back into the depths of the dimly lit TV rooms and I went nervously back to work.

This time, I tied a large rock to the end of my throwing line and succeeded in heaving it over a fine branch high in the



Down the basement steps I bounded.

cottonwood. Then I tied the free end to my antenna and threaded it up through the branches and back to the ground on the far side of the tree.

By about 3:30 AM all the wire was out . . . zigzagging around the common area, ending up tied securely to a sapling in front of the complex.

The next night, after dinner, I hurried down to the basement to give the new antenna a try. Flip on the rig. Bandswitch to 40 CW. Tune past the nets, through the RTTY boys, around the keyboard "QRQ heads," and zero-in on 7040 kHz to try to stir up a low-power ragchew. The tiny changeover relay in the Argonaut "snipped" away happily as I buzzed off my "CQ."

But before I could sign, I heard a distinct "PING," and then another. Signal strength fell markedly . . . and so did my mood as I pondered the cause. PIGEONS! Rammed! 28 gauge wire is no match for a determined pigeon's strafing run. Now what? Permanent QRT?

Two weeks later, a new and



In seconds I was in the hall closet attacking a man-sized stack of ham magazines.

fiendishly creative plan rose into my mind. There was a way to build a completely people- and pigeon-proof, multi-band antenna . . . one so cunningly installed that no one could trace it to the "strange-eyed fellow" in No. 103.

Once again I waited anxiously for darkness, this time with two-hundred feet of small-gauge coax and a big butcher knife. Sundown came with a good cloud cover.

I began beneath the basement window, carving a thin trench with the knife. The grass was high and wet. Mosquitos, chiggers, and gnats were abundant, and the ground was luxuriant with granite boulders. Combine those problems with the 95-degree heat and drenching humidity, and I faced a task that makes laying a transatlantic cable child's play.

The first night I buried only 80 feet of transmission line; the next night, another 80. By the weekend, the line extended across the common ground, under the big hedge on the property line, along a narrow footpath, and out into the city park.

Saturday morning I picked up

several Slinky toys at the hardware store. By measuring the length of wire in each loop and multiplying that by the number of turns, I was able to arrive at the number of turns required to approximate a half wavelength on each of my favorite bands: 40, 20, and 10 meters. When you extend a coiled-up half wavelength of wire to about one eighth wave in stretched-out length, it acts like an electrical quarter-wave; perfect for a vertical antenna. I cut three Slinkys to size and wired them together at the base so they could be fed simultaneously with the center conductor of the coax.

The next step was to cut a number of radial wires to about 33 feet in length. I ran out of energy after twenty four of them and concluded that I had reached the optimum number. I placed the radials and the Slinky verticals in my black bag, and, by 11 PM, was creeping from tree to tree, across the common ground, through the hedge, and into the park. After some searching, I located the stub of coax which projected from the end of my laboriously carved transmis-

sion-line trench. So carefully had I replanted the grass and weeds in the slot after inserting the coax that there was no sign of my work.

The moon was dimmed by the fat, fuzzy clouds which marched lethargically across the sky. Working furiously, I cut the slits and placed the radials in the traditional fan-like arrangement. I attached the center conductor of the coax to the conjunction of the three Slinkys, and fastened the shield to the point where the radials joined. I then smeared the entire feed point with silicone glue, let it dry, wrapped the connections with tape, and applied another layer of the rubber-like glue. I wasn't about to let any moisture ruin the product of all that drudgery.

Stepping back to admire the job, I looked down on the three small coils which were just detectable in the tall grass below the big tree. Next, I tossed a roll of 15-pound-test monofilament line up and over a strong branch that stood out horizontally from the trunk of a nearby tree. Twice more I threw the roll, then cut each length of each to the top turn on each of the three Slinkys. A small screw-eye twisted into the tree trunk served as the tie-down point for the elevating lines.

"At last," I thought, "my antenna farm is about to spring into action." I drew each coil up to its full operating height with the raising line, and tied it temporarily in position. The verticals, joined at their bases, stretched up and outward like a huge candelabra. My work done, I slithered through the dewy grass back to my townhouse and my station, which now beckoned.

Some say, on dark nights, something rises up in the park behind Seven Trails West. It's a beast with three long necks that quivers and gleams in the moonlight; a creature that roams at night and hides by day. I listen to the stories and smile. A monster lives just 200 feet from my ham shack desk. And it's mine. **HRH**

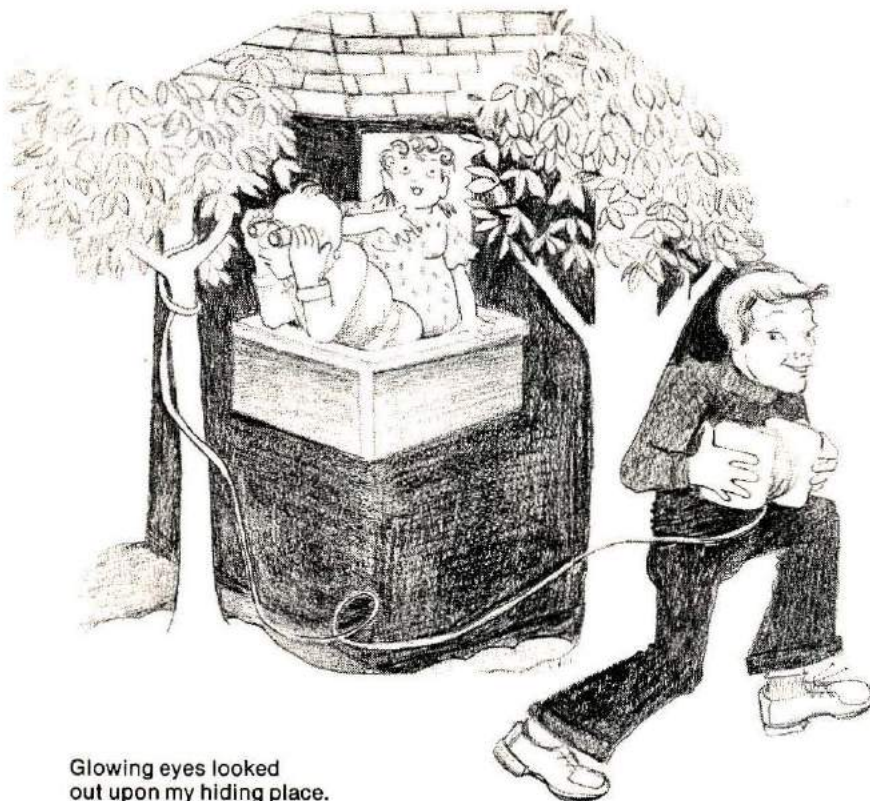

Glowing eyes looked out upon my hiding place.

A VERY SHORT RECEIVING ANTENNA

*A compact receiving system
for the cliff-dweller*

BY DOUGLAS BLAKESLEE, N1RM



An advertisement for a commercial antenna currently appearing in electronics publications is headlined "Good Listeners Keep A Low Profile." It's true, especially if you inhabit an apartment. Hams with very limited — or no — space for antennas are at a severe disadvantage. Not too long ago *Ham Radio Horizons* outlined some tricks for limited-space antennas.¹ For both transmission and reception, such antennas are definitely second-class cousins to even simple arrays erected by those who have the acres and poles needed for profitable antenna "farming." For transmitting, the *Horizons* article outlined many of the solutions available. For receiving, however, the apartment dweller need not suffer with second-class performance.

Evolution of an idea

It seems that every time I have a good idea, I find that someone else has thought of it first. When I read Jim Fisk's piece about the voltage probe antenna in *ham radio*² some years ago, I was intrigued with the concept and I stored the idea away for future reference. At the time I didn't know how appropriate coupling and gain circuits might be designed.

The unobtrusive voltage-probe antenna mounted on a window sill.

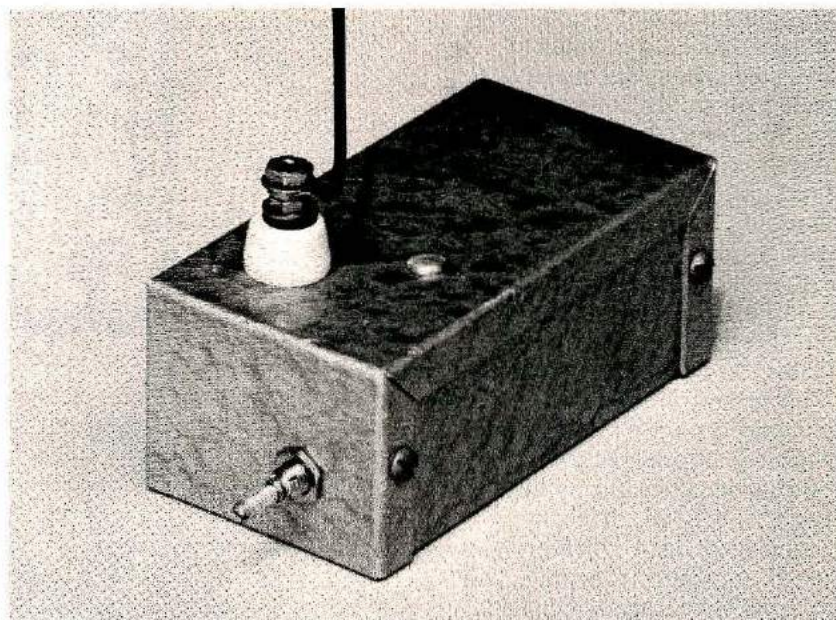
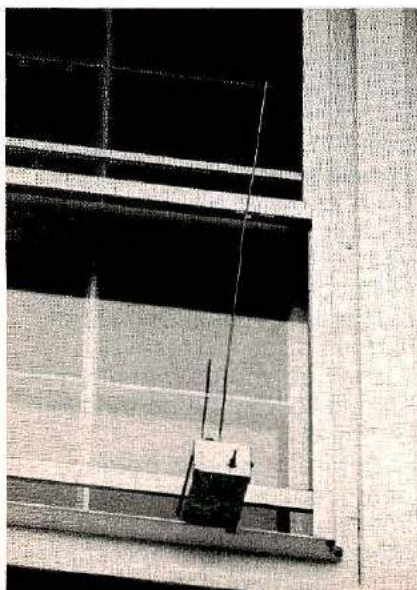

The preamp assembly is mounted in a Minibox. The screw adjustment is for the broadcast-band trap.

During my conversation with John Kraus, W8JK, for an interview article,³ he said that short transmitting antennas could be very inefficient if losses weren't controlled, but small receiving antennas could work very well, as evidenced by the loop-stick antenna in a-m broadcast radios. A light came on in the back of my head. Of course! A voltage-probe antenna could be made quite simply with today's solid-state components. Performance should be good, especially at low frequencies. All that was needed was to combine the high-impedance input circuits used in frequency counters with the broadband rf-amplifier designs being used in test equipment and some solid-state transmitters.

Circuit design

Most electronic projects do not work the first time — at least not mine! The circuit that evolved for the cliff dweller antenna is the result of some cut-and-try experiments. The configuration and circuit are a starting point for those who like to experiment. The antenna is shown in block-diagram form in Fig. 1. (Block diagrams are

often used to simplify electronic circuits so that they may be readily understood.) The antenna is a short, 30-cm (12-inch) wire connected to the circuit ground by means of a high-value resistor. Voltages developed across the resistor by incoming signals are sampled by a preamplifier that provides moderate power gain and an appropriate output impedance level for connection to a transmission line.

Impedance matching in the classic sense of the term is not used at the input to the preamp. Full-sized transmitting and receiving antennas usually have a low or moderate impedance at the feed point, typically 70 ohms for a dipole and 300 ohms for a folded dipole. Impedance matching is employed to ensure maximum power trans-

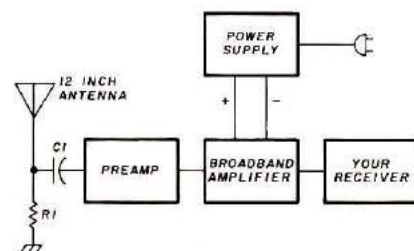
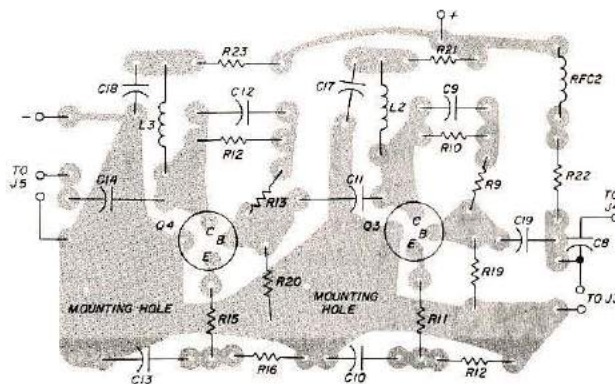
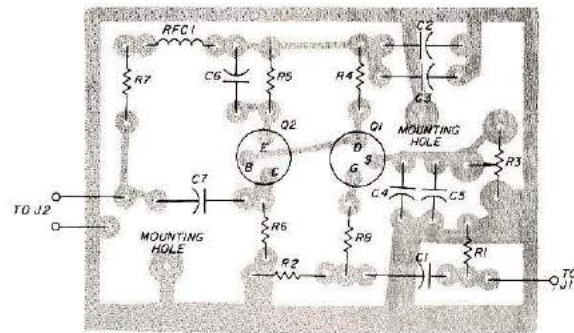

Fig. 1. Block diagram of the voltage-probe antenna system.

swing without distortion. The follower, Q2, is a bipolar transistor whose purpose is to provide an output impedance near 50 ohms. Power to the preamp is provided through the signal cable. An rf choke, RFC1, passes dc voltage while blocking rf energy. Thus, the output cable simultaneously carries the radio frequency signals from the preamp while conducting dc power to the unit.

The preamplifier feeds a combination wide-band amplifier/power supply, Fig. 3. The amplifier is a design by Wes Hayward, W7ZOI, first described in private correspondence⁴ and later in print.⁵ The two amplifier stages, Q3 and Q4, use heavy feedback. Feedback, coupling energy from the output of a circuit to its input, is used in many ways (and to good advantage) in radio circuitry. In an oscillator, it is feedback that produces continuous oscillation. In audio and rf amplifiers, feedback helps to reduce distortion, to eliminate gain variations between amplifying devices, and to establish



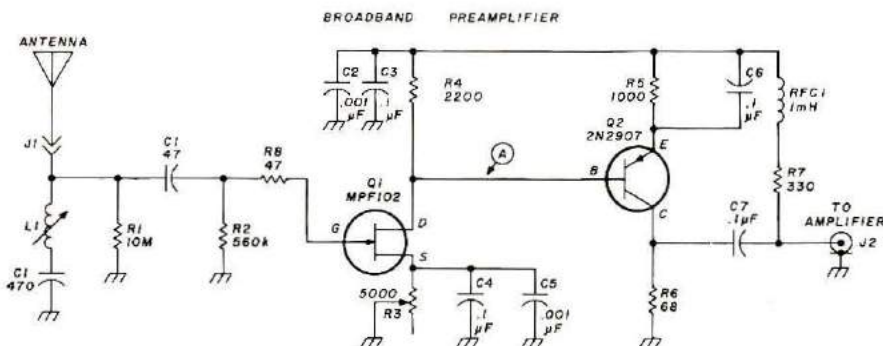

Fig. 2. Schematic diagram of the preamplifier. Point A is a voltage-test point, as described in the text. Resistors are 1/4-watt sizes.

fer from a transmitter and to a receiver. In this voltage-probe antenna, power transfer is ignored. The voltages developed across the resistor are coupled via a capacitor to the input of the preamp, which has a very high input-impedance. Because capacitive coupling is used, the unit is essentially independent of frequency across the high frequency spectrum. Or, to say it another way, it's very broadband.

Of course, a very short antenna does not extract as much

energy from a passing radio wave as does a full-size antenna. Thus, it is necessary to provide some amplification of the incoming signals if this short wire is to approach the performance of its larger counterparts. A broadband preamplifier, with a gain of approximately 20 dB, is used for this purpose. The choice of an appropriate gain level posed a design problem which is still not fully resolved. The shorter the antenna, the higher the gain that is needed. But the

amount of energy extracted by the antenna varies with frequency, with low frequencies providing the lowest signal levels. Thus, the preamplifier gain needs to be a tradeoff between the frequency range and the length of the antenna. Too little gain will degrade signal strength while too much gain can cause distortion in the preamp or amplifier from

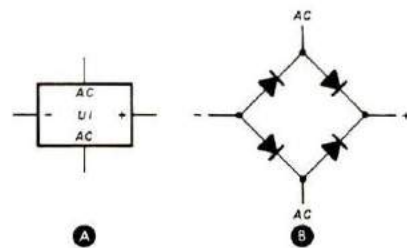

Fig. 4. A bridge rectifier for the power supply can be an assembly such as U1, (at A) or, you can make your own by wiring four diodes (RS 276-1102) as shown at B.

strong signals, generating spurious signals and causing overload of your receiver front end.

Circuit components

The circuit diagram for the preamplifier is shown in Fig. 2. Any voltage developed across R1 is coupled to the input of Q1 through a capacitor, C1, with which R2 forms an RC (resistance-capacitance) network to attenuate energy in the low-frequency range. Signals in the broadcast band can be particularly troublesome if you live within a mile or two of a transmitter. Signal strengths can be more than enough to limit the effectiveness of a voltage-probe antenna. This was a problem in my case, so a series trap consisting of L1 and C2 was added to null out a broadcaster on 910 kHz. If you have no broadcast stations for neighbors, L1 and C2 can be eliminated.

The fet input stage is directly coupled to an emitter follower, Q2. R3 is used in the source lead from Q1 to adjust the drain current through the FET to provide maximum signal

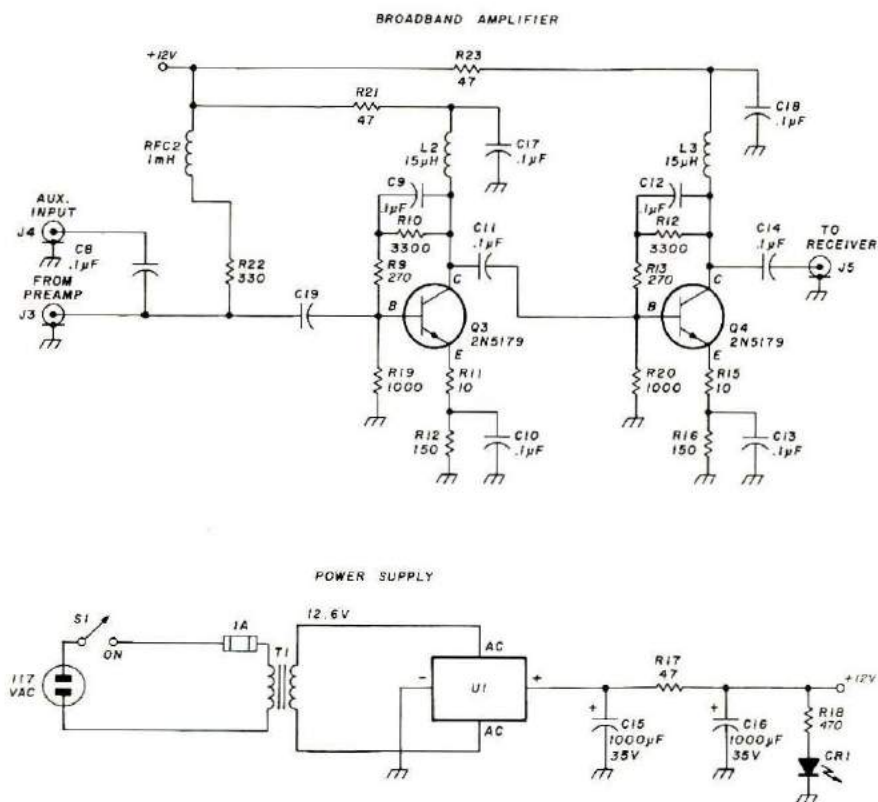

Fig. 3. Schematic diagram of the amplifier/power supply. Resistors are 1/4-watt.

wool. Then mount the components a few at a time. Bend the leads slightly to hold the parts in place. Then, touch the soldering iron to the component lead and the copper of the circuit board simultaneously.

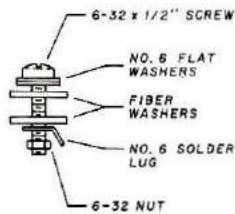

Fig. 7. A homemade feed-through insulator.

After a second or so, apply a small dab of rosin-core solder. As soon as the solder has melted, remove the iron. Inspect the solder joint. If it has a smooth, shiny appearance, all is well. But if it looks lumpy or dull, it is probably a "cold" joint which may fail electrically or mechanically. Reheat any cold joints until the solder flows freely. After soldering each group of components, check to be sure that no bridges of solder have splashed between adjacent leads on the circuit board.

The preamplifier was housed in a 41 × 50 × 101 mm (1-5/8 × 2 × 4 inch) (Radio Shack 270-239) Minibox. Any enclosure of similar size is suitable. I used a small ceramic feed-through insulator from my junk box to mount the antenna. Such components are rapidly gaining dinosaur status. A suitable mount can be made using two fiber washers, as shown in Fig. 7. Keep the lead from the antenna input to the preamp circuit board as short as possible.

A 127 × 177 × 50 mm (5 × 7 × 2 inch) aluminum chassis (Bud AC-402 or Radio Shack 270-246) was used to house the power supply and broad-band amplifier. Any chassis or Minibox of similar size is suitable. In fact, the unit could be made somewhat more compact if desired. After the mounting holes are drilled, the

chassis can be given a coat of paint in your favorite color. All wiring in the unit, other than the circuit board, is made point-to-point, using tie strips for connection points. Be sure to observe the proper polarity when mounting the rectifier assembly and filter capacitors. Do not connect the lead from C16 to the broadband-amplifier circuit board until you start the adjustment procedure. The leads from the circuit board to the phono connectors should be kept short. Otherwise, lead lengths are not critical.

Adjustment

When all wiring of the preamp and amplifier/power supply is complete, recheck all connections. Connect a volt-ohmmeter (VOM) — set to measure resistance on the highest scale — between the plus terminal of C16 and the chassis. The ohmmeter should kick to a low resistance reading and then slowly return to an indication of more than 10,000 ohms. (This action is caused by the battery in the ohmmeter charging C16.) If the reading is low, you have a defective com-

ponent or short-circuit connection.

If the resistance reading is high enough, set the VOM to read a voltage of approximately 20 volts. Turn on the power switch; the voltage across C16 should be between 18 and 22. If this check is successful, turn off the power and connect the lead from C16 to the amplifier circuit board. Connect the cable from the amplifier/power supply to the preamplifier. Turn the power on again, and check the voltage at the junction of RFC1 and R5 in the preamp. It should be approximately 12 volts. Make a note of the actual reading. Move the voltmeter lead to the junction of the drain lead of Q1 and the base lead of Q2, point A in Fig. 2. Adjust R1 until the VOM indicates half of the voltage reading noted above. This completes the adjustment procedure.

Results and improvements

In some 20 years of hamming, my first try with the voltage-probe antenna was perhaps the biggest shock. Direct comparison with a full-size, ground-mounted vertical

This prototype version of the preamp uses the isolated-pad construction technique.

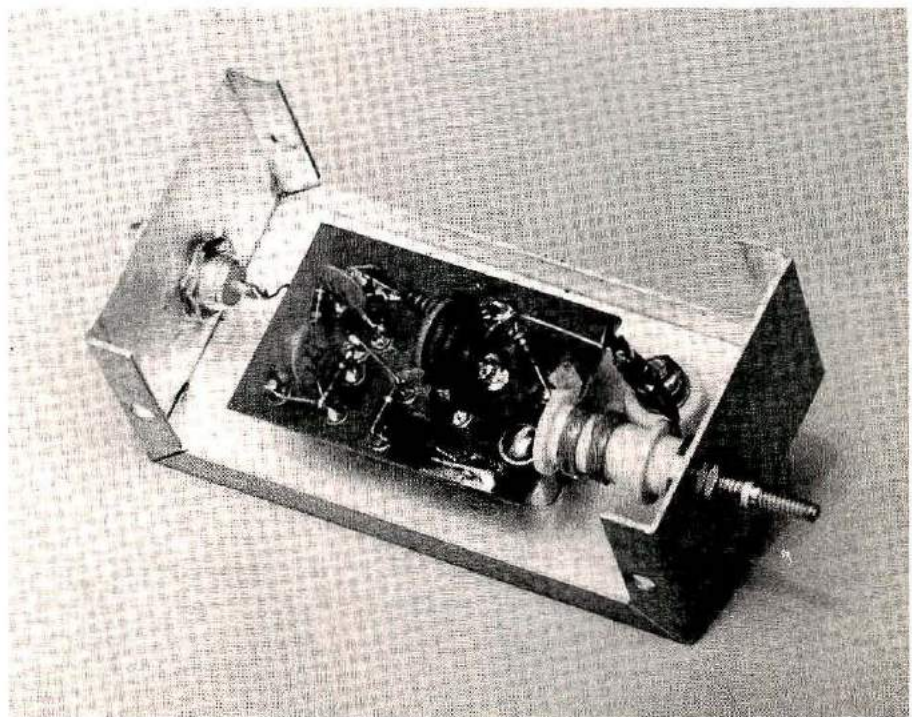

with thirty-two radials showed 40-meter signals originating 3000 or more miles away were often of equal strength on the voltage-probe unit. On 80, they were down some 10 to 15 dB.

Listening to 80-meter ssb signals from Japan, one of the most difficult paths from Connecticut, I found signal strength down somewhat but the signal-to-noise ratio was always better than from the full-size antenna. Ground-mounted verticals can be rather noisy, but they're great for transmitting. Long Beverage antennas of 1000 feet or more will produce better receiving results on long paths. I don't have a Beverage for comparison; the results with a few inches of wire will probably prevent lazy me from tacking several thousand feet of copper out through the trees!

Also, the short antenna didn't seem to follow the rules

of antennas as I know them. Placing the short antenna in a horizontal or vertical position made little or no change in incoming signal strength. Some simple experiments with ground planes (not connected directly to the preamplifier assembly) showed no change in signal strength, whether they were in place or not. Also, the short antenna did not show

signs of detuning even when brought within two inches of a large metal structure. The results obtained with the short antenna inside a wooden-frame house were not observably different from those obtained outdoors. In a cement apartment house with metal supports, the system performed better when the antenna was set out on a window sill.

Above 20 meters, a few feet of wire thrown out the window will suffice. This is fortunate because the performance of the voltage-probe antenna deteriorates as the frequency goes up. Very strong low-frequency signals produce distortion in the amplifying system. This distortion creates harmonics (multiples of the basic frequency) and distortion products (multiples of the basic frequency which mix, adding and subtracting to produce many new frequencies). The basic design is "wide open;" that is, it contains no selectivity, other than input-circuit components selected to reduce the strength of signals below 1.5 MHz.

Active antennas are in their infancy. It's an exciting new field which takes only a few hours in the workshop to enter. *ham radio* magazine has published articles about using short antennas in arrays for directivity.⁹ Clearly, the major problem is to build an amplifier which will handle strong signals without overload, while retaining sufficient sensitivity.

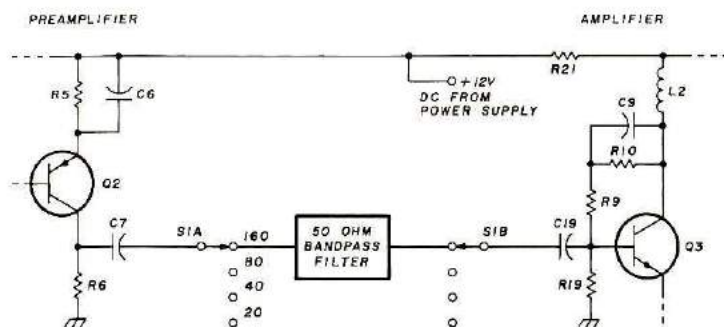
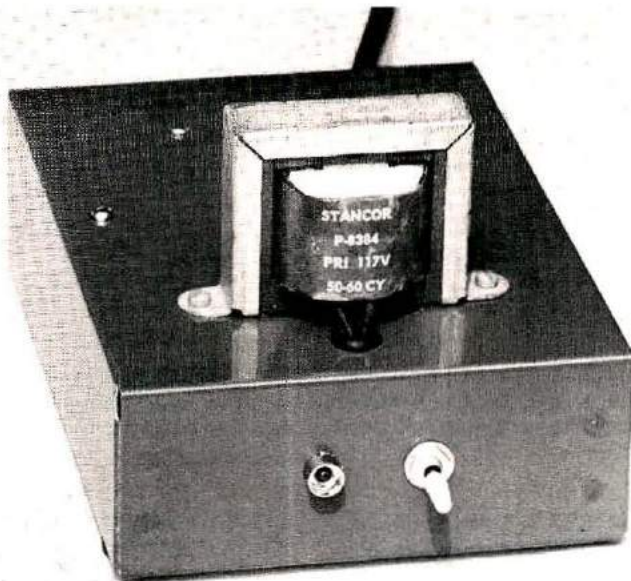

Fig. 8. Circuit changes needed to insert bandpass filters between the preamp and amplifier to improve performance. All components are those used in Figs. 2 and 3 except for S1, which is a two-pole, four-position, rotary type (RS 275-016).

Table 1. A parts list for the preamplifier/amplifier/power supply. RS numbers given are Radio Shack part numbers.

C1-C14, C17-19, incl.	0.1 μ F, low-voltage disk ceramic capacitor (RS 272-120 series)
C15, C16	1000 μ F, 35V electrolytic capacitors (RS 272-1019)
CR1	Light emitting diode (RS 276-041)
J1	Ceramic feedthrough insulator or homemade equivalent (see Fig. 7)
J2-J5, incl.	Phone connector (RS 274-346)
L1	Adjustable inductor, 45 to 100 μ H (J. W. Miller 42A825CBI)
L2, L3	16 μ H inductor, 5 turns No. 26 (0.4 mm) enamel wire on 250 μ jumbo ferrite bead (G. R. Whitehouse, 15 Newbury Drive, Amherst, New Hampshire 03031)
Q1	JFET (RS 2036)
Q2	PNP (RS 2022)
Q3, Q4	NPN, 2N5179
R1, R2, R4 - R23, incl.	Carbon resistors, 1/4 or 1/2 watt (RS 271-000 or 271-1300). If 1/2-watt resistors are used, they must be mounted vertically on the circuit board.
R3	Linear taper control, PC mount (RS 271-217)
S1	SPST (RS 275-612)
T1	117V primary, 12V secondary (RS 273-1385, 273-1505, or Stancor 8384)
U1	Bridge rectifier, 100V, 1 A (RS 276-1152)



Front view of the power supply/broadband amplifier. An LED lamp is included to indicate when the power is on.

This is an area of development which has occupied communications-receiver designers for the last 15 years. Many of the amplifier-circuit developments for receiver design are directly applicable to active antennas.

My simple unit can be improved by placing selectivity between the preamp and the amplifier. Bandpass filters for

the ham bands of interest are a worthwhile improvement for those who wish to use a short antenna for serious hamming. Suitable filters can be chosen from the ARRL *Data Book*.¹⁰ The use of such filters introduces new complexity into the receiving system because a bandswitch is now required. Also, a separate conductor is

The broadband amplifier is the circuit board to the left. The power supply components are mounted using tie strips (Radio Shack 274-688).

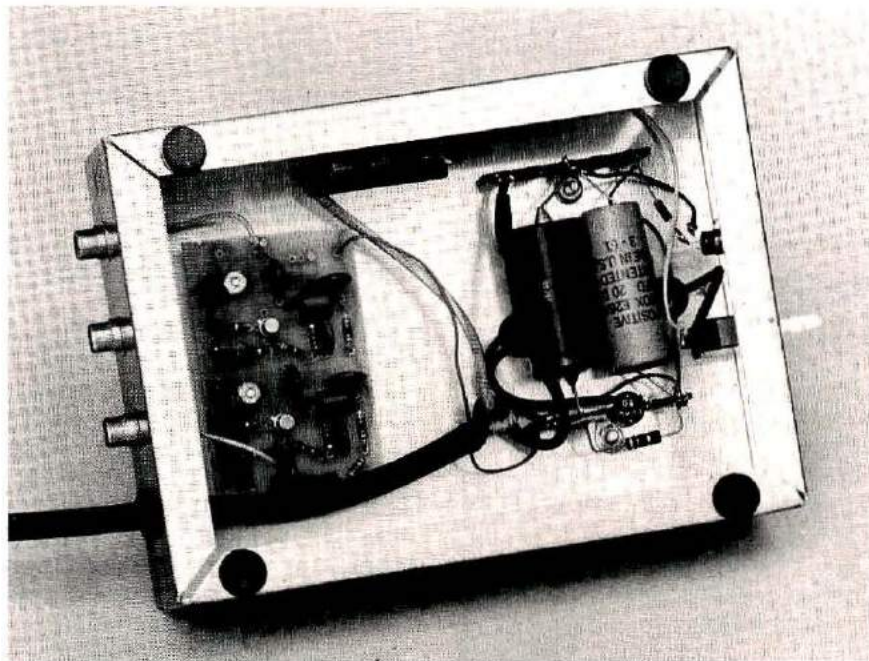

needed to pass dc power to the preamp, as the signal cable cannot be used, see Fig. 8.

For those with an experimental bent, the field of active receiving antennas will be an exciting subject. Radio theory as it is now understood would seem to preclude similar developments of efficient short transmitting antennas, but, who knows. Meantime, it's fun to say, during an 80-meter QSO, "my receiving antenna here is only 12 inches long, OM."

References

1. Joseph V. Carr, K4IPV, "Antennas For A Tiny Yard," *Ham Radio Horizons*, November, 1977.
2. James R. Fisk, W1HR, "Voltage Probe Receiving Antenna," *ham radio*, October, 1970.
3. Douglas A. Blakeslee, N1RM, "HRH Interviews Dr. John Kraus, W8JK," *Ham Radio Horizons*, December, 1978.
4. Wesley H. Hayward, W7ZOI, Personal correspondence.
5. Wesley H. Hayward, W7ZOI, and Milton F. DeMaw, W1FB, *Solid State Design For The Radio Amateur*, 1977, ARRL, Inc., available for \$7 plus \$1 shipping and handling, from Ham Radio's Bookstore, Greenville, New Hampshire 03048.
6. Douglas A. Blakeslee, N1RM, "Power To The Projects," *Ham Radio Horizons*, December, 1977.
7. G. R. Whitehouse, 15 Newbury Drive, Amherst, New Hampshire 03031 offers the two circuit boards, as well as a minikit consisting of the four transistors, 2 jumbo beads, 2 each 1 mH miniature rf chokes, and a ceramic feed-through insulator.
8. Alfred F. Stahler, W6AGX, "Isolated Pad Circuit-Board Construction," *QST*, May, 1973. Drills available from Stahl, 5521 Big Oak Drive, San Jose, California 95129 or any Vector Electronics distributor, parts P116 and P118.
9. Henry S. Keen, W5TRS, "Selective Receiving Antennas: A Progress Report," *ham radio*, May, 1978.
10. Milton F. DeMaw, W1FB, *ARRL Electronics Data Book*, ARRL, Inc., 1976, available for \$4 plus \$1 shipping and handling from Ham Radio's Bookstore, Greenville, New Hampshire 03048.

HRH



Puts the World at Your Fingertips

Get your antenna high enough with a TRI-EX tower and bring the world to you.

Receive signals which you have never heard before.

Send your call to other HAMS who have never heard you.

A TRI-EX tower will give you listening power...calling power...and stay-up power that means durability.

Durability comes from TRI-EX's 25 years of building quality towers. These years of experience combined with the latest engineering knowledge and materials are used to design and build towers which stay up under the antenna loads and wind speeds specified. After manufacture our steel towers are hot dipped in molten zinc (galvanizing). All exposed steel is covered inside and out - including the inside of tubing.

Our aluminum towers are self-resistant to corrosion. TRI-EX TOWERS makes them all: GUYED TOWERS, CRANK-UP TOWERS, FREE STANDING TOWERS, STACKED TOWERS.

And we will install a tower on your site, upon request.

Call, or write TRI-EX now for information on the right TRI-EX tower for you. We will send you our complete list of prices, delivery dates, installation information and the name of your nearest dealer. Call TOLL FREE.

Call our New Number
1-800-528-6050, Extension 1025

In Arizona, dial:
1-800-352-0458, Extension 1025



7182 Rasmussen Avenue, Visalia, California 93277

a remotely controlled antenna switching system

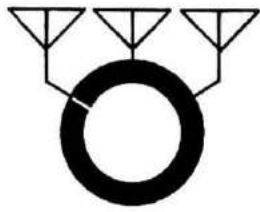

three hundred feet of coax required to do the job also taxed the ham budget more than I liked. The answer to the problem seemed to be to use a remotely controlled antenna switch located near the top of the tower. The existing run of coax would be fed into the switch while short coax lines would be connected to each antenna. The desired antenna could then be selected by a control box in the ham shack.

While there are commercially available switches that would do a good job and prevent the maze of feedlines, their high price tags made me think in terms of a homemade device. The circuitry that was selected

BY DAVID MALLEY, K1NYK

It is fairly common for hams to have multiple antenna systems in order to obtain coverage of several Amateur bands. This applies to both the old-timer and newcomer alike, since the Novice might have an 80-meter inverted vee, and dipoles or beams for the 15- and 10-meter

bands. After nearly twenty years in the hobby, I finally acquired a tower which now supports a tri-band beam (20, 15, and 10 meters), a 2-meter beam, and the old standby 80-meter vee. With such a variety of antennas, three transmission lines coming into my somewhat small basement shack would present a problem. The

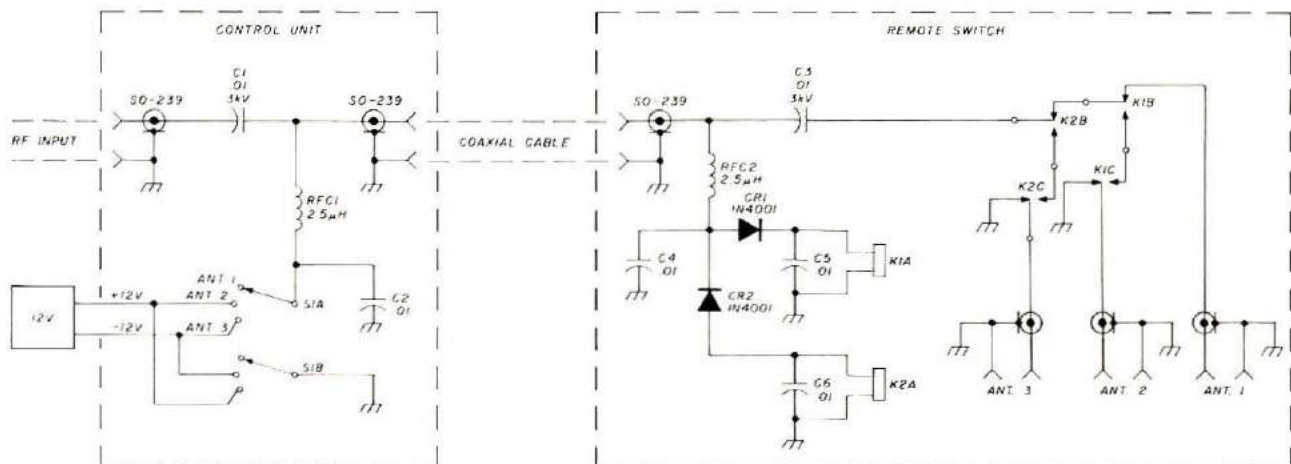

Fig. 1. Schematic diagram of the remote antenna-switching system. The relays are Radio Shack 275-208 with 12-volt dc coils. The power supply must have both the positive and negative terminals above ground.

is relatively simple to understand and can be easily built by the newcomer. Another attractive feature is that all of the parts are readily available. Information on where to obtain the necessary components is presented later in the article. I

circuit. RFC1 and C2 are used to prevent the transmitter's rf energy from floating around inside the control unit.

Now for the remote switch itself. When there is no dc voltage present, the normally closed relay contacts provide a

The opposite effect occurs when minus 12 volts is applied and K2 energizes antenna 3.

Note that antennas 2 and 3 are grounded when not in use to avoid static charge build-up and thus reduce the possibility of damage to your equipment.

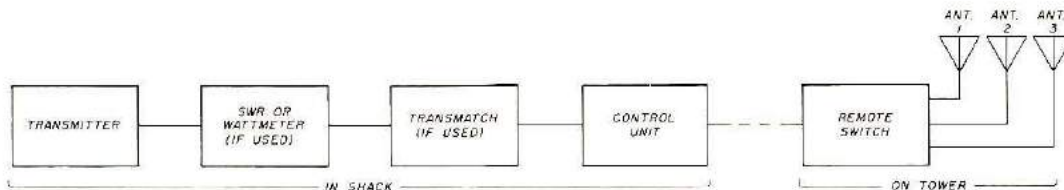

Fig. 2. Suggested equipment connections when the remote switching system is used with a wattmeter (or SWR bridge) and a matching network.

make no claim as to the originality of the circuit used: it can be found in the *ARRL Radio Amateur's Handbook*. However, a few modifications have been made to improve operation and add an extra element of safety.

How it works

The circuitry for both the control unit and the remote switch is shown in **Fig. 1**. The 12-volt power supply was already on hand. However, many circuits have appeared in the literature. Whether you buy or build the power supply, a one-ampere rating is more than adequate. *Caution:* Both the positive and negative output terminals must be ungrounded to prevent shorting out the supply when it is connected to the coaxial cable.

The two-pole, three-position, antenna-selector switch applies zero, plus 12 volts, or minus 12 volts to the center conductor of the coax cable going to the remote switching box. **Fig. 1** shows the selector switch in the zero-voltage position. By studying the wiring, you will see that the other positions determine the voltage polarity. By using the coax to carry this voltage, you save the need for a separate wire going up to the remote switch itself. C1 serves as a blocking capacitor to prevent the supply voltage from entering the transmitter and possibly being shorted to ground in the final tank

straight-through connection to antenna 1. In my case, that was chosen to be the tribander, as it would be the most frequently used. Positive voltage passes through diode CR1 to the K1 relay coil and activates antenna 2. This voltage is prevented from reaching K2 by the reverse-polarized diode, CR2.

The selector switch, rf choke, and capacitors fit into a small aluminum box with plenty of room to spare. A single-wafer switch can be used as long as it has two circuits and three positions.

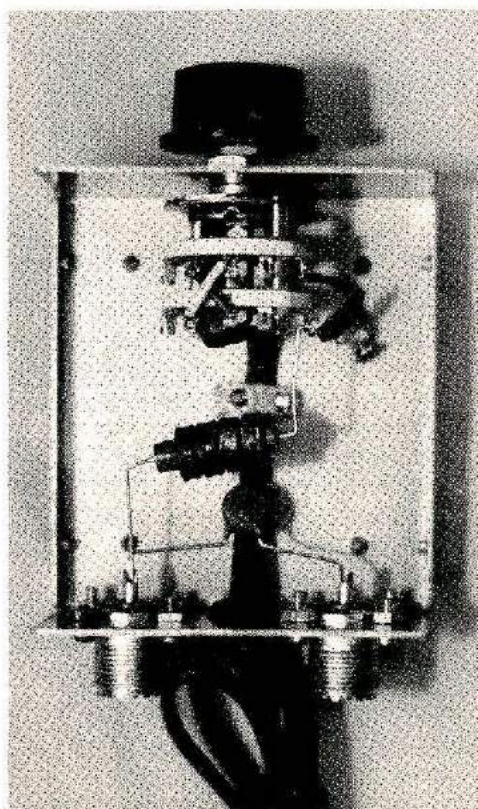

This capability is a result of using dpdt relays, and is one of the modifications made to the original design. In my case, only one-half of the triband driven element is always above ground. A Blitzbug* is inserted in the transmission line at ground level to discharge excessive static from that element.

Blocking capacitor C3 stops the dc voltage from going up to the antennas while RFC2 and C4 keep rf away from the relay coils. The values of both C1 and C3 were increased from their *Handbook* values of 0.001 μ F. This reduces the reactance of the combined series capacitance and eliminates the initially high standing wave ratio (SWR) on 80 meters. Typically, the SWR increases from about 1.3:1 to 1.5:1 as a result of putting the switch in the line. This is a minor increase and is not considered important. Either 52 or 75 ohm coax is suitable for connecting the control unit to the remote switch. A voltage drop of only 0.3-0.4 volt was measured over a 31 meter (100 foot) length of RG8/U.

Construction hints

The control unit is enclosed in a 10 x 8 x 6 cm (4 x 3 1/4 x 2 1/4 inch) aluminum box

*Blitzbug is the registered trade name of a lightning arrester manufactured by Cushcraft Corporation.

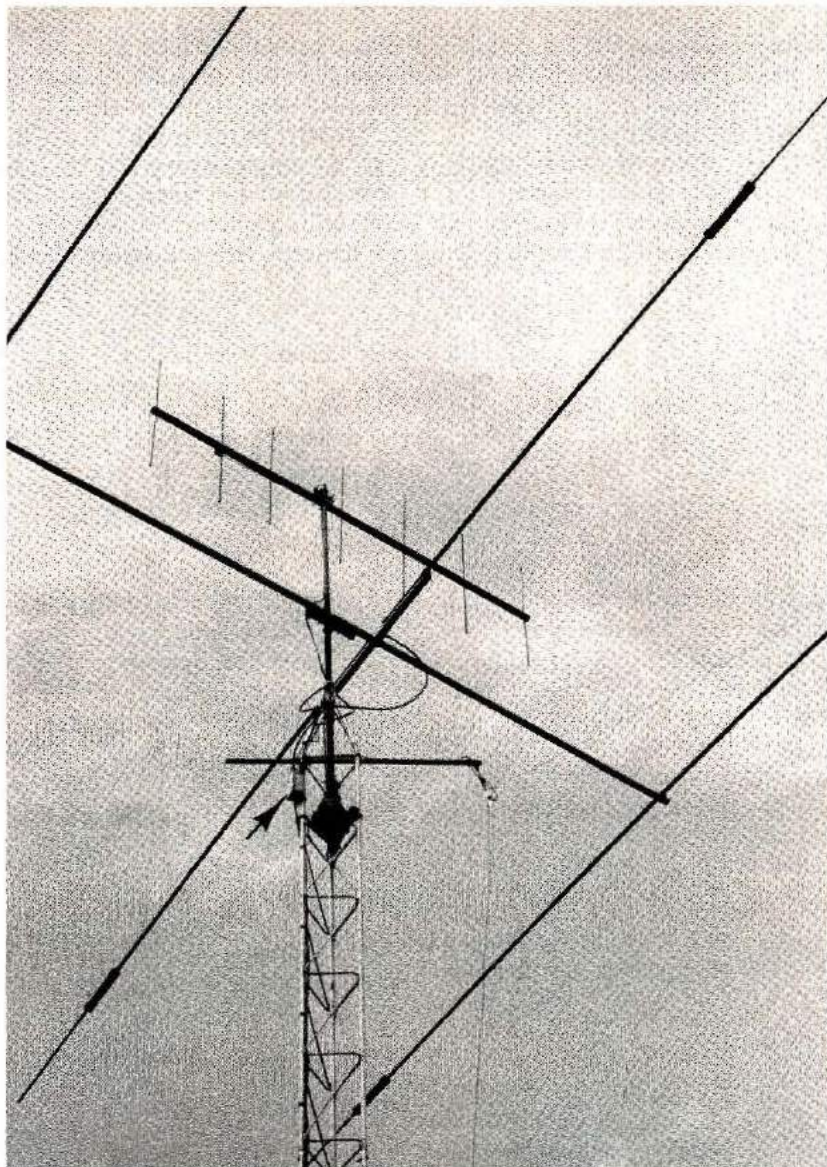

The remote antenna selector box is mounted atop the tower, near the antennas it feeds (arrow). The seams in the box, and the coaxial cable connectors, should be weather-proofed with sealant to prolong the life of the relays.

(Radio Shack 270-251). This is a convenient size because it has enough room to assemble the components required. SO-239 chassis connectors are used for the input and output. A six-position ceramic rotary switch was on hand, but any two-circuit, three-position switch would be fine. The junkbox also provided the rf chokes, but they can be purchased from electronic supply houses. Both C1 and C3 are 3 kV-rated capacitors and are available at supply houses. This voltage rating is necessary, because a high SWR or high transmitter power can create very high voltages at certain points along the

transmission line. Placement of components in the box is not critical, and the photograph shows the parts layout I used. The application of dry transfer labels completed the assembly.

The aluminum box for the remote switch (Radio Shack 270-238) measured $13 \times 8 \times 5$ cm ($5\frac{1}{4} \times 3 \times 2$ inches). A slightly larger enclosure, however, would have made construction simpler. Again, parts placement is not critical. The use of 10-ampere relay contacts allows running 2 kW PEP without arcing problems. Of course, a lower current rating is satisfactory if high power is not contemplated. The

relays that I selected (Radio Shack 275-208) have 95-ohm coils and draw 0.125 amp when 12 volts is applied.

When the wiring has been completed and checked, connect the two units with a length of coax and make sure that the relay contacts energize the proper antenna coax connectors. This can be done by listening for the relay clicks as the selector switch is rotated, or by using an ohmmeter to determine if the antenna connectors are disconnected from ground when activated. Occasionally, the relay contacts may be sticky and not close properly. If this should happen, disconnect the control unit and apply 12-18 Vac from a transformer secondary directly across the input coax (or terminal) on the remote switch for a few seconds. Normal contact-cleaning procedures can be used if the relays are not sealed.

If you plan to use a Transmatch or Matchbox, it should be located before the control unit. Many matching circuits do not have dc continuity between their input and output terminals and would prevent the control voltage from reaching the remote switch. Experience indicates that for an SWR bridge or wattmeter to function properly, it should be placed before the control unit (refer to Fig. 2). Before mounting the switch outdoors, the enclosure should be well sealed along mating edges and corners to keep moisture out. Silicone sealant, such as used for bathtub caulking, seems to be ideal for this application and is available in small tubes from hardware and discount houses.

Finally, I should point out that the remote switch allows some amount of convenience in disconnecting the rigs from the transmission line that enters the house, since only one is present. This also implies that only one Blitzbug (or equivalent) need be purchased.

HRH

WHERE RELIABILITY AND ACCURACY COUNT

INTERNATIONAL CRYSTALS 70 KHz to 160 MHz

CRYSTAL TYPES

- (GP) for "General Purpose" applications
- (CS) for "Commercial" equipment
- (HA) for "High Accuracy" close temperature tolerance requirements

International Crystals are available from 70 KHz to 160 MHz in a wide variety of holders.

WRITE FOR INFORMATION

International
Crystal Manufacturing Co., Inc.
guarantees
every crystal against defective
materials and workmanship for
an unlimited time, when used in
equipment for which they were
specifically made.

HOLDER TYPES

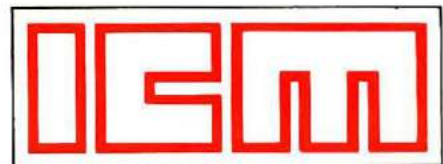
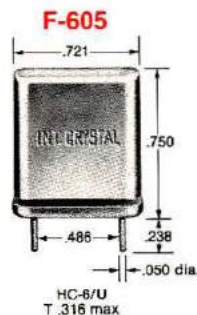
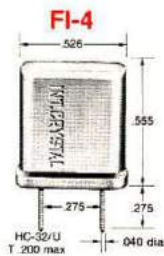
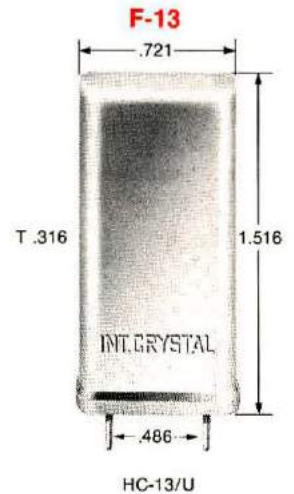
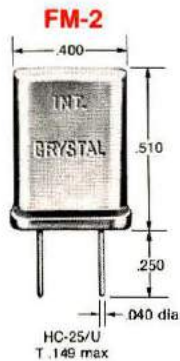
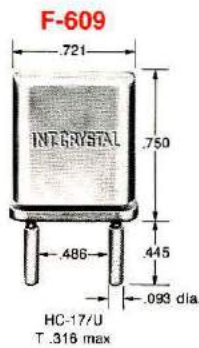
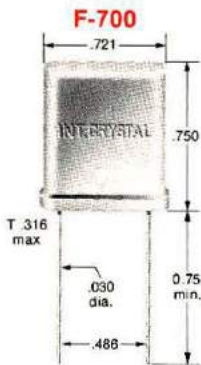

INTERNATIONAL CRYSTAL MFG. CO., INC.
10 North Lee / Oklahoma City, Okla. 73102

Log of W2QPQ/1

BY JULIAN JABLIN, W9IWI



July 6, 0100Z — W2QPQ/1 set up at Pine Mountain State Park, Vermont. Transmitter final input, 2 watts; receiver, direct conversion; antenna, long wire; frequency, 40-meter band.

What kind of vacation can it be when you take along a child not yet two-years old — even to a cabin in the woods? Just as she does at home, Helen will be cooking and making beds, and we will take along enough disposable diapers to fill the back of the station wagon. You can't imagine all the things that she thought were necessary. But when she saw my little ham rig she objected. Helen: "You're not taking an Amateur Radio, are you?" Me: Stony silence, meaning that I darned well am. Helen: "When will you get a chance to use it?" Me: "I'll have plenty of time. Gary takes a nap every afternoon, so we'll be tied down to the cabin then. What about after supper . . . where can we go in the evening? And how much reading can you do?" Final compromise: I will operate only during his nap and an hour after supper.

July 6, 0230Z — No contacts.

We did not see the cabin before we signed up for it. "Pine Mountain" sounded good. I visualized a place miles from any source of QRM, and Vermont is pretty. The cabin had all the conveniences — outside! No electricity. That gave me the idea of taking along a low-powered rig. Some quick arithmetic convinced me that a couple of lantern batteries would last the whole two weeks if I did not transmit too much. The transmitter-receiver, plus an electronic keyer, a hundred feet of No. 18 wire, and a spool of 22-pound-test nylon fishing line, an antenna tuner, plus phones, and there was my station. After we arrived at the cabin (it was

pretty) I found a couple of trees about 75 feet apart, heaved the fishing line into them, tied on the antenna wire, and I was in business. But, no contacts. Strange — there should be a lot of guys looking for Vermont!

July 7, 1900Z — Still no contacts. July 8, 0238Z — W3SPA — Baltimore — Jerry — my RST 559, his RST 599.

First contact. So I am getting out, anyway. Jerry is running 200 watts to a pair of 6146s (good luck!) in a rig he built himself. I guess if you want a real CW-only rig these days you

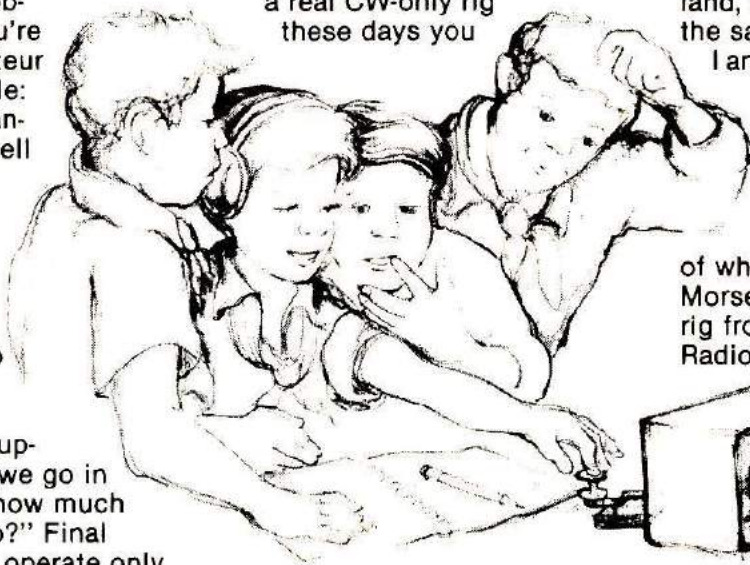

have to homebrew it. We were having a good QSO when someone with a gallon* opened up on top of me and wiped me out. That's what happens with a low-powered rig, and you learn to accept it.

July 10, 1945Z — VE2AAV — Ontario — Ted — my RST 589, his RST 599.

Ted is a radio maintenance man at an RCAF base somewhere in Ontario. We had a long rag-chew, mostly without QRM, about vacations and fishing. He is planning to go on leave next month. Maybe I ought to investigate the fishing while I'm here. Ted says that I could learn to fly-cast without much trouble, and he's really enthusiastic about it. I told him

*Gallon = big signal; a kilowatt transmitter.

about open-party-boat fishing on Long Island Sound; they don't have anything like that where he is. We signed when his lunch hour was over — that's when he operates. Wonder how he handles a key and a sandwich at the same time! We made a sked for tomorrow . . . same time, same frequency.

July 12, 0200Z — WB8SDD — Oberon, Ohio — Peter — my RST 599, his RST 569.

Today I helped a Boy Scout show off his ham station. Peter is at Scout camp near Cleveland, and he is running about the same kind of operation that I am here, except that today he had a bunch of would-be hams watching him make contacts, and I had to say hello to Tommy, and Lou, and Harry, and all the rest, all of which Peter translated from Morse into English. He built his rig from a kit — part of his Radio Merit Badge requirement — and it sounded pretty good. We both wondered why his 35-watt signal was

weaker than my two watts — must be conditions. Food at camp is awful; he did a three-day hike with only the bare necessities to get along in the woods; his parents cannot understand why he does not write longer letters; they have something called "Middle School" before Junior High where he comes from. You learn all sorts of things on the Novice portion of the band!

July 14, 1935Z — No contacts.
July 15, 0200Z — No contacts.

It pays to check things out every once in a while. And, like Peter, my Boy Scout contact of the other day, I should learn to be prepared. The reason for all those "no contacts" was no antenna. Coming out of the cabin this morning, I happened to look up and noticed that the antenna wire had broken off

just where it was tied to the nylon line. The feeder portion had stuck in the tree, and I was putting power into about 25 feet of wire slanting up into the branches. I got everything down and — of course — had not brought a soldering iron along. A trip to the Park Superintendent's maintenance shop took care of that. When the antenna went up again, it was cut a little closer to a half-wave at 40 meters. It was all completed in time for my regular schedule with Ted. He suggested a lightweight rechargeable soldering iron, plus a few simple tools, if I ever do this kind of trip again.

July 16, 2040Z WD4GHY — Ft. Lauderdale, Florida — Bob — my RST 569, his RST 589.

Sometimes CW can lead to a little mix-up, or maybe people hear what they want to, not what you say. Bob is retired, used to live in Bay City, Michigan. Some retirement! He's busier than ever before, working on his boat, his house, and his rig. Then he asked me how old I am and what I do for a living. Maybe he got the figures all mixed up, or maybe my keying is not all that perfect. Anyway, he somehow got the idea that I am well along toward retirement myself, and began boosting Florida. "Give it some thought, Steve . . . you'll be down here with us having a ball in a few years!" Just then, Gary woke up, squalling to be changed, and I had to QRT — Helen tells me a father should have a hand in every aspect of child-rearing. So I told Bob that I had to go, but did not tell him why. It would have involved too many explanations!

July 17, 1950Z — VE1PB — Halifax, Nova Scotia — Burt — my RST 559, his RST 589.

Right after signing with Ted I worked another Canadian. When we had gone through the opening amenities, Burt asked

me what I do, and I told him. Seems that he sells the same kind of stuff in the area around Halifax, and he kept asking questions about the specific lines I handle, and what's good about them. It sounded as though he might want to change manufacturers, and was looking for some unbiased information. I was a little worried about the trend the QSO was taking — where's the line between social conversation and business in a situation like this? So I suggested that we continue by mail after I got back home. I just wonder if — along with the other QSLs I expect to find when I return — there will be one from the Friendly Candy Company.*

July 17, 2350Z — KZ5HC — Canal zone — Frank — my RST 339, his RST 599.

Wow! This is a record, for me, for miles per watt! I'll have to check in an atlas just how long a haul it was. It was a very brief contact; Frank had a phone-patch sked on for 2400Z and was spending a few moments in the CW portion of the band, just listening, when he heard my CQ. That was lucky — with low power you do not usually call CQ. It pays off better to listen and answer someone who's calling. We used most of the time just to get the calls, RST and QTH information exchanged. My signal must have been very bad down there, and he had a lot of patience. That's what makes a good operator. I'll have to add a special "thank you" on my QSL to him.

July 18, 1830Z — W1LRP — Stacey, New Hampshire — Dan — RST 599 both ways.



*The FCC, Federal Communications Commission.

Real DX. There cannot have been more than 120 km (75 miles) between us. But it was a fun contact; you take the locals with the exotic ones and enjoy them all. When Dan told me that he is a farmer, I joked and asked, "Antenna farmer?" Well, whatever else he grows, he sure grows antennas! I'd like to see his 40-meter rhombic — three wavelengths on a leg!

July 18, 1910Z — K5LTA — Huntsville, Alabama — Ruth — my RST 579, her RST 599.

That was a tough QSO. Started easily enough, exchange of basic information, then she began to warm up the key. Well, I stuck with it for a while, and we were really moving the Morse back and forth. Finally I peaked out, but she was still going strong, so I gave up and sent, "Pse QRS" — no lame excuses about poor readability, either. From there on it was pretty good, but I was still scribbling fast. She did say that she was rag-chewing only as a break from handling traffic. Somewhere along the line Helen heard me muttering, and looked over my shoulder at the scratch pad on which I was making notes. Then she said nastily, "What's the matter, honey, a woman too much for you?"

July 19, 2100Z — W1CAF — Altonville, Vermont — Henry — my RST 599, his RST 599.

I figured that this would be the last contact. We were to leave for home tomorrow, and there would be a lot of packing to do. Helen has been very good about the fact that my one-hour hamming periods have stretched well beyond our agreed time, and I wanted to

give her as much help as possible in getting ready for the trip back. At any rate, I tuned around and there was a terrifically loud signal, a good note, but the worst CW I'd ever heard — slow, with uneven dots and dashes and some long pauses. I called him and after a bit he came back to me. He was in Altonville, about

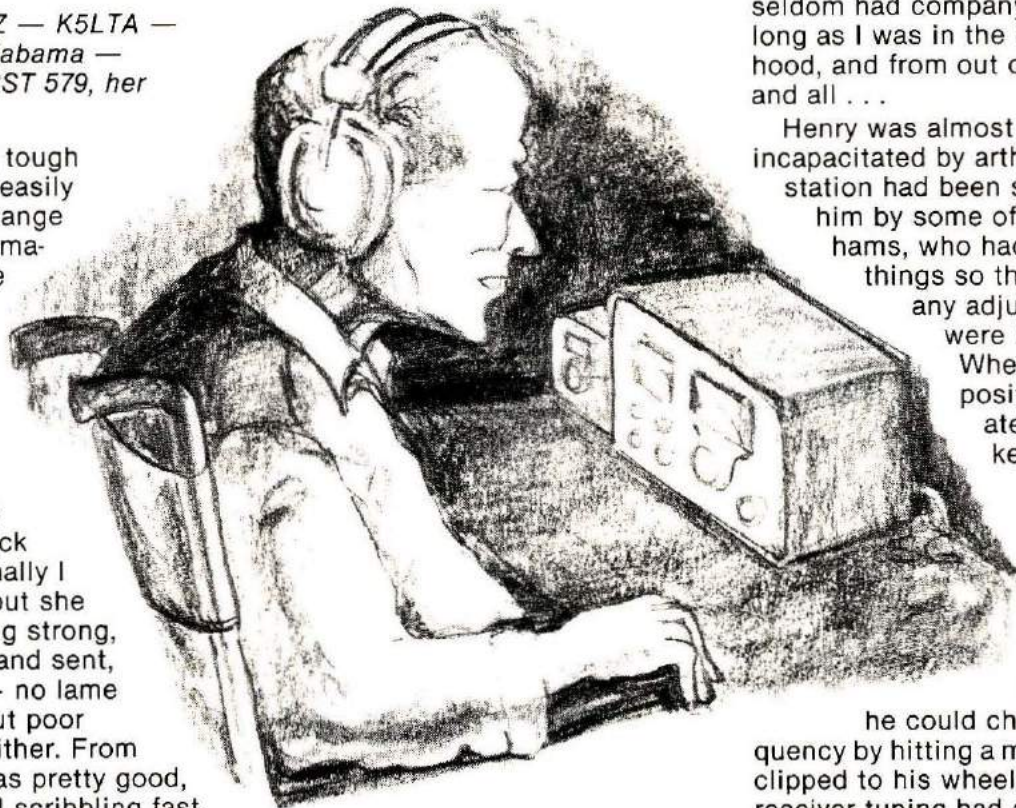

five miles down into the valley. It's a big town (or a small city) where we had done some shopping and one night saw an outdoor movie while Gary was asleep in the back seat. Henry said that he'd heard me on but had not called me before this.

After some talk, I invited Henry up to the park to see our cabin and my rig, but he said that he couldn't. Then I told him that I had to go to Altonville to buy some disposable diapers for the trip home, and that I could stop in to say hello to him in person. A long pause, then he said okay, and gave me his address.

It was a big old frame house, and I could see the 40-meter dipole strung from the eaves to

a tree in the back yard. A woman let me in and said that Henry was in back. I went to an enclosed back porch and saw a little old man in a wheel chair, hunched up in front of a rig. The rear was arranged in a semi-circle so that he could reach almost everything without moving very much. After inviting me to sit down, he told me that he had not really wanted me to come — he seldom had company — but as long as I was in the neighborhood, and from out of town and all . . .

Henry was almost totally incapacitated by arthritis. His station had been set up for him by some of the local hams, who had arranged things so that hardly any adjustments were necessary. When he was in position to operate, his housekeeper turned everything on with one switch. The transmitter was crystal controlled, and

he could change frequency by hitting a microswitch clipped to his wheelchair. The receiver tuning had a string drive which came out to a big wheel near his less-crippled hand. He keyed the transmitter by *blowing* on the cone of a little speaker which was in a sort of VOX circuit, which his buddies had also worked out and installed. No wonder his CW was slow and uneven!

We talked for a while, then I remembered Helen waiting for me in the cabin, so I said so long and left. When I got back to Pine Mountain, before I unplugged everything, I gave Henry a call and sent "73" several times. No answer, but perhaps he was listening.

July 19, 2350Z — W2QPQ/1, Pine Mountain State Park, Vermont, closed station.

HRH

& MAPS CALL TOLL

FOR YOUR BOOKS, TAPES



ARRL Publications

ARRL Radio Amateur's Handbook Newly revised & jam-packed with everything from basics to latest developments. I.N. 10081 9.75

ARRL Radio Amateur's License Manual The most up to date compilation of rules & regulations. Covers from Novice to Extra Class. I.N. 10012 4.00

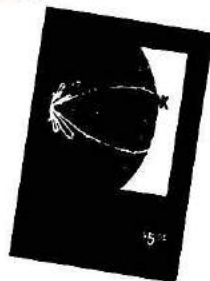

ARRL Antenna Handbook Complete instructions for building antennas of all types. I.N. 10026 5.00

ARRL World Map I.N. 10099 3.50
LCF Calculator Slide rule type calculator to compute resonant frequency, etc. A great aid! I.N. 10062 3.00

Electronic Data Book All you need to know about Filter design, RF circuit data, antennas and feeding info & more. I.N. 10027 4.00

Learning to Work With Integrated Circuits Build a digital voltmeter/freq. counter while learning about IC's. I.N. 10060 2.00

Single Sideband for the Radio Amateur Covers theory and practical how-to-built ideas. I.N. 10017 3.00

FM and Repeaters for the Radio Amateur Learn all about FM and repeaters from this handy book. I.N. 10014 5.00

Solid State Design for the Radio Amateur Packed with information for practical use of solid state devices. I.N. 10061 7.00

Solid State Basics Pure solid state information and practical basics for today's ham. I.N. 10037 5.00

Specialized Communication Techniques for the Radio Amateur Covers ATV, SSTV, FAX, RTTY, satellite communications and more. I.N. 10028 3.00

ARRL Radiogram Message Pads I.N. 10007 75 ea.

ARRL Special Operating Kit Consists of ARRL Ham Radio Guide, full color U.S. area call map, ARRL log book, 70 ARRL radiograms. I.N. 10063 6.50

ARRL Ham Radio Operating Guide Brush up on good operating practices with this ready reference source. I.N. 10025 4.00

Getting to Know Oscar from the Ground Up. Explains all about the use of amateur satellites, how to use them and where to find them. I.N. 10059 3.00

80 meter DXing Handbook. Contains 4 sections on propagation, antennas, station equipment, and operating practices. It's filled with solid practical experience. I.N. 26307 4.50

The Amateur Radio Vertical Antenna Handbook The first book for amateurs solely about vertical antennas. It is full of information. I.N. 26316 5.00

The Challenge of 160 The unique operating characteristics are explained and there are tips on building simple equipment. I.N. 26312 4.95

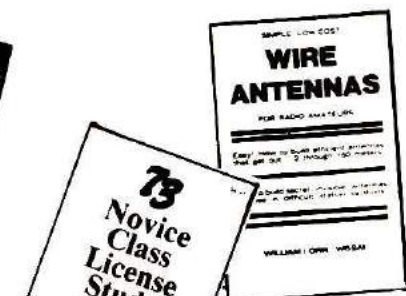

Hints and Kinks New ideas written by hams themselves. This is full of practical ideas and tips that they have used successfully. I.N. 10029 4.00

Radio Frequency Interference A new book to help everyone understand RFI. It covers all from good neighbor relations to simple technical cures for RFI. Helps identify and solve problems. I.N. 10083 3.00

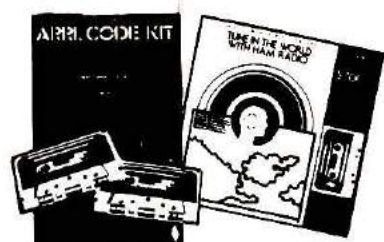

ARRL Code Kit Upgrade your Novice or Tech License with these 2 60 min. cassettes with speeds of 5, 7.5, 10, & 13 wpm. Instruction book included. I.N. 10046 8.00

ARRL Log Books spiral bound books.
 Large I.N. 10015 1.75
 Small I.N. 1002075

Tune in the World with Ham Radio Learn all about amateur radio with a text and a morse code cassette. For the beginner studying for the Novice exam. I.N. 10031 7.00

Understanding Amateur Radio A must guide for the newcomer, it explains in simple language elementary principles of electronics & tells how to build low cost equipment. I.N. 10016 5.00

Radio Publications, Inc.

Beam Antennas Handbook by Wm. Orr, W6SAI I.N. 26200 4.95

Wire Antennas by Wm. Orr, W6SAI I.N. 10058 4.95

All About Cubical Quad by Wm. Orr, W6SAI I.N. 26201 4.75

The Truth About CB Antennas by Wm. Orr, W6SAI I.N. 26202 5.95

EIMAC's Care and Feeding of Power Grid Tubes I.N. 26205 4.95

The Antenna Handbook I.N. 26207 6.95

VHF Handbook by Wm. Orr, W6SAI I.N. 26203 5.95

Better Short Wave Reception by Wm. Orr, W6SAI I.N. 26204 4.95



Ameco Books

Communicate with the World with Ham Radio NP-1. I.N. 24825 6.95

Ameco 7-01 Question and Answer Guide for the Novice Exam 1.00

Question & Answer for Advanced Class Exam 16-1 I.N. 24809 1.50

Question & Answer for Extra Class Exam 17-1 I.N. 24801 1.50

Radio Amateur Theory Course 102-01 I.N. 24812 4.95

Radio Electronics Made Simple I.N. 24800 2.50

Logbook I.N. 24807 1.50

Commercial Radio Operator Theory Course 15-01 I.N. 24808 6.95

Commercial Q&A License Guide Etc. 4 10-01 I.N. 24805 1.95

Commercial Q&A License Guide Etc. 3 9-01 I.N. 24804 2.95

Commercial Q&A License Guide Etc. 1, 2, & 8 8-01 I.N. 24803 1.50



Other Great Books

Collins Radio Co. SSB Amateur Single Sideband I.N. 10092 4.95

73 Magazine VHF Antenna Handbook I.N. 26303 4.95

73 Magazine Novice Class Study Guide I.N. 26300 4.95

73 Magazine General Class Study Guide I.N. 26301 4.95

The Beverage Antenna Handbook I.N. 0000 5.00

K3CHP DX QSL Guide I.N. 26313 3.95

Amateur TV in a Nutshell I.N. 26322 5.00

How to Make Better QSL's I.N. 26304 4.95

The Complete Handbook of Slow Scan TV I.N. 30518 9.95

Remember, you can Call Toll Free: 1-800-633-3410 in the U.S.A. or call 1-800-292-8668 in Alabama for our low price quote. Store hours: 9:00 AM til 5:30 PM, Monday thru Friday.



Long's Electronics



FREE 1-800-633-3410 OR

ORDER BY MAIL TODAY

Tab Books

- Novice Class Study Guide I.N. 30517 5.95
- General Class Study Guide I.N. 30519 7.95
- Advanced Class Study Guide I.N. 30522 5.95
- Extra Class Study Guide I.N. 26302 5.95
- A Beginners Guide to Microprocessors I.N. 30502 5.95
- 57 Programs and Games in Basic I.N. 30501 7.95
- The "Computer" Book I.N. 30509 7.95
- Ham Radio Incentive Licensing Guide I.N. 30503 4.95
- Programming Microprocessors I.N. 30508 6.95



- Third Class FCC License Study Guide I.N. 30514 6.95
- First Class FCC License Study Guide I.N. 30542 7.95
- Electronics Data Handbook I.N. 30549 5.95
- Impedance I.N. 30520 5.95
- Basic Digital Electronics I.N. 30527 4.95
- Basic Electronic Problems Solved I.N. 30545 4.95
- Tower's International FET Selector I.N. 30500 6.95
- Second Class FCC Encyclopedia I.N. 30535 7.95
- How to Use AF and RF Signal Generators I.N. 30512 5.95
- Electronics Unraveled I.N. 30531 5.95
- Master Transistor/IC Substitution Handbook I.N. 30510 7.95
- RF and Digital Test Equipment You Can Build I.N. 30521 5.95
- Commercial FCC License Handbook I.N. 30542 7.95
- IC Projects for the Amateur and Experimenter I.N. 30543 5.94
- How to Read Electronic Circuit Diagrams I.N. 30546 6.95

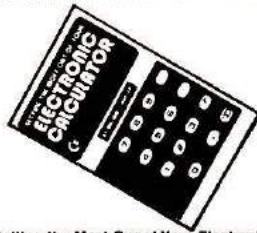

- Getting the Most Out of Your Electronic Calculator I.N. 30528 4.95
- How to Install Everything Electronic I.N. 30552 7.95
- The 2 Meter FM Repeater Circuit Handbook I.N. 30537 6.95
- Modern Applications of Linear IC's I.N. 30530 9.95
- Mobile Radio Handbook I.N. 30534 4.95
- Basic Electricity and Beginning Electronics I.N. 30536 5.95
- Practical Solid State DC Power Supplies I.N. 30515 6.95
- Electronic Conversions, Symbols, and Formulas I.N. 30524 5.95
- Tower's International Transistor Selector I.N. 30507 6.95
- Electronic Test Equipment and How to Use It I.N. 30526 4.95

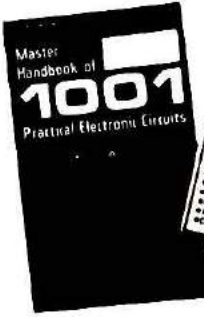

- Master Handbook of 1001 Practical Electronic Circuits I.N. 30523 9.95
- Master Handbook of Ham Radio Circuits I.N. 30506 8.95
- Complete Short Wave Listeners handbook I.N. 30532 6.95
- Master OP-AMP Applications Handbook I.N. 30505 9.95
- C.E.T. License Handbook I.N. 30513 8.95
- Effective Trouble Shooting with EVM and Scope I.N. 30525 5.95
- Handbook of Electronic Tables I.N. 30548 4.95
- Homebrew HF/VHF Antenna Handbook I.N. 30504 5.95
- How to Be a Ham I.N. 30533 3.95

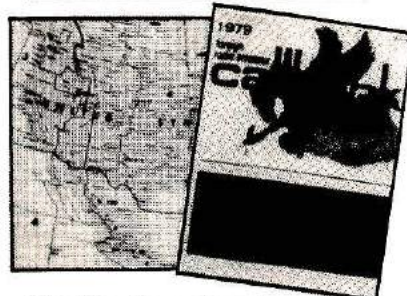
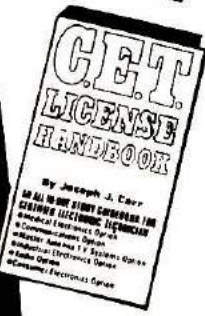

Radio Amateur Callbook

- Map Library A complete set of maps, prefix world map, great circle chart, map of N. America, and world atlas. I.N. 10005 3.75
- Callbook binders
 - U.S. callbook red I.N. 10054 6.00
 - DX callbook blue I.N. 10055 6.00
 - DX Callbooks I.N. 10001 14.95
 - U.S. Callbooks I.N. 10000 15.95
 - Prefix map of North America I.N. 10004 1.25
 - Zone prefix map of the World I.N. 10022 1.25
 - Great circle chart of the World I.N. 10003 1.25

RSGB Books

- Oscar - Amateur Radio Satellites The comprehensive book on amateur satellites illustrated with pictures and charts I.N. 10059 8.50
- VHF-UHF Manual If you have any interest above 30 MHz, then get this book. It covers everything in this field I.N. 26208 13.95



TRAINING PACKAGES TAPES

Crack the code and ace your exam by studying the new way with our selection of cassettes. Just drop them into a cassette player and study anywhere easily and quickly. You'll have great results.

- 73 cassettes
- Novice Theory Tapes prepare you for the FCC novice exam. Clearly presented material can be reviewed many times I.N. 26306 15.95
- Code Tapes
 - 5 word per min. Blitz Tape I.N. 26308 4.95
 - 6 word per min. Blitz Tape I.N. 26309 4.95
 - 13 word per min. Blitz Tape I.N. 26310 4.95
 - 20 word per min. Blitz Tape I.N. 26311 4.95



- Teco Code Practice Tape are guaranteed for life.
- Novice tape I.N. 31461 3.95
- 5 wpm tape I.N. 31450 3.95
- 7 1/2 wpm tape I.N. 31451 3.95
- 10 wpm tape I.N. 31452 3.95
- 13 wpm tape I.N. 31460 3.95
- 15 wpm tape I.N. 31454 3.95
- 17 wpm tape I.N. 31455 3.95
- 20 wpm tape I.N. 31456 3.95
- 22 wpm tape I.N. 31457 3.95
- 25-30 wpm tape I.N. 31458 3.95
- 35-40 wpm tape I.N. 31459 3.95

- Ameco Code Tapes
 - Junior Code Course #100-T Covers start to 8 wpm I.N. 24819 4.95
 - Advanced Code Course #103-T From 8 to 18 wpm I.N. 24821 4.95
 - Senior Code Course #101-T Double length covering the Junior and Advanced Courses start to 18 wpm I.N. 24820 8.95
 - Extra Class Code Course #104-T Covers from 13 wpm to 22 wpm includes FCC type exam I.N. 24822 4.95
 - General Class QSO tapes #105-QT 12, 13, 14, & 15 wpm I.N. 24827 4.95
 - Extra Class QSO tape #106-OT 19, 20, 21, & 22 wpm I.N. 24826 4.95
- Katronics
 - QSO Code Tapes Covers 7, 10, 13, & 15 wpm. Be ready for the new FCC exams I.N. 28906 4.95

Remember, you can Call Toll Free: 1-800-633-3410 in the U.S.A. or call 1-800-292-8668 in Alabama for our low price quote. Store hours: 9:00 AM til 5:30 PM, Monday thru Friday.



Long's Electronics



MAIL ORDERS: P.O. BOX 11347 BIRMINGHAM, AL 35202 • STREET ADDRESS: 2808 7TH AVENUE SOUTH BIRMINGHAM, ALABAMA 35233

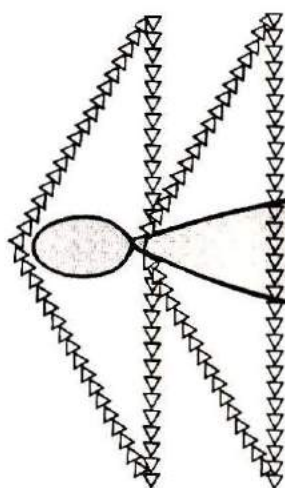

The Delta-Loop Antenna Rides Again

BY HARRY LEEMING, G3LLL

After I moved to a new location in November, 1976, my thoughts turned to antennas. At that time the only band offering a chance of transatlantic QSOs was 20 meters. A beam was considered essential if contacts were to be at all pleasurable.

After much thought and consideration I decided to try a delta-loop beam, and after some trial and error this resulted in the inverted-V, two-element delta loop described in *Ham Radio Horizons* for June, 1978.

The delta loop is really an out-of-shape quad and seems to retain the quad's qualities. Like the quad, it is famed for good results when mounted at modest heights, and this is usually attributed to a low angle of radiation. Perhaps this is true, but vhf tests do not seem particularly convincing. There may be other reasons. Perhaps the loop construction results in a "contained field" with less signal lost in nearby objects. Loops are certainly quiet on receive, and it would seem sensible that an antenna which picks up less interfer-

ence from local electrical wiring in the receive mode also wastes less rf on transmit by not pumping it into the same wiring. Certainly loop antennas do seem to produce fewer RFI problems and more DX, and, after all, that is what most of us want. Theoretical arguments aside, to me even a one-element delta loop seems to be at least an S-unit ahead of the most carefully trimmed and oriented multi-band dipole.

To return to the story — after having used the 20-meter, two-element delta loop for a few months, the sun broke out in spots, and 15 meters opened. I temporarily interlaced a 15-meter driven element inside the 20-meter-element. This made a very satisfactory antenna, but, like *Oliver Twist*, I still wanted more. Next, a reflector was put in place. This gave me some gain toward the U.S. By this time winter was approaching and antenna activity for the next few months was confined to putting things back every time they blew down!

The new loop

With the advent of spring 1978, the delta loop was long overdue for rebuilding, and to ensure future reliability I decided to completely dismantle it and start again. Previous rough measurements

had seemed to indicate that the length of wire required was somewhat more than that normally used for quad loops. Therefore, I decided to make more accurate measurements so as to help anyone who wished to duplicate the antenna. The previous construction was of No. 22 AWG (0.6-mm) wire for the loops, but this could not withstand storms. I selected copper/nylon braid for the new antenna because of its strength. This brought a bonus in that it proved to have much less tendency to "whistle" in strong winds.

I then decided to make the antenna cover the three main long-distance bands, and first of all the driven elements were installed and experimentally altered in length until they were resonant in the center of the three bands. The required length of copper/nylon braid varied, depending upon the shape of the antenna, but the eventual shapes and lengths that proved satisfactory are indicated in **Fig. 1**. No measurements of impedance were made, but various handbooks would lead one to expect that the impedance of the driven element operated on its own would be somewhere in the region of 100-150 ohms. This seems to be the case, as feeding the driven element

directly with 75-ohm coaxial cable results in an SWR of between 1.5 and 2 to 1.

At the time that I was rebuilding the antenna, a friend, G4GCT, was experimenting with various designs of balun transformer, and measurements of their loss were made. Some samples showed a slight loss, and this loss increased when they were encapsulated. For comparison purposes an expensive commercial balun was obtained and was found to be surprisingly inferior to most of the home-brewed samples, giving a loss of almost 1 dB. This may not seem like much, but losses add up, and even 1 dB brings the output of a 200-watt transmitter down by 30 watts or so. Give the same inattention to two other lossy points and you are down to half power.

Being in the hi-fi trade, I have long since proven the extreme efficiency of ferrite cores in stopping rf from flowing on the surface of leads entering hi-fi amplifiers. A quick check with a dummy load fed with a length of coaxial cable wrapped round a ferrite core showed no loss of power or increase of SWR, and so, while good results had

been obtained without a balun of any kind, I decided to install a ferrite-core, choke-type balun. The coaxial cable was disconnected from the antenna, wrapped six times round two 38-mm (1½-inch) stacked cores, and reconnected to the antenna. It works! Previously, I had been able to hear a distorted version of my voice in the headphones while transmitting on my FT-101. The balun cured this, so it obviously has stopped rf from coming down the outside of the coaxial feeder. It seems, therefore, that a couple of 50-cent cores will do all that a \$20 balun will, except give a 1 dB loss!

Being eager to get back on the air, I used the antenna in its one-element form (firing east/west) for some weeks. Very good results were obtained, and I wondered how I could retain this feature, and yet have a good front-to-back ratio and gain toward the U.S. when I wanted it. A note in the Radio Society of Great Britain's booklet *Amateur Radio Techniques* referred to a solution advocated by W6AJZ. Why not bring the reflector adjustment into the shack? W6AJZ's method is shown in Fig. 2. A

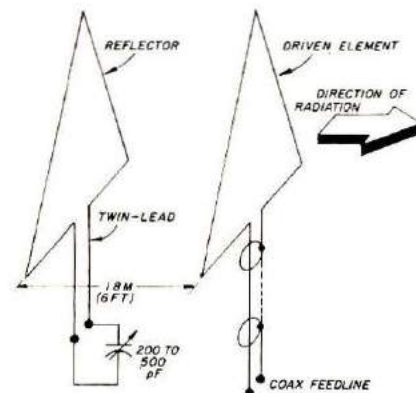

Fig. 2. The basic configuration of a two-element delta-loop beam. The tuning capacitor adjusts the reflector to resonance for best gain and directivity of the beam. It can be located in the shack at the end of twin-lead feeder which is a multiple of a half-wavelength, as discussed in the text.

length of transmission line runs from the center of the reflector to the operating position. If this line is electrically an exact number of half wavelength long, it effectively brings the center of the reflector into the shack so that adjustments can be carried out in comfort.

A second 20-meter element was slung from the fm broadcast antenna which is mounted on top of the mast. It was positioned so that at the bottom it was around 3 meters (10 feet) from the driven element. One electrical wavelength (approximately 17 meters, or 58 feet, allowing for the velocity factor) of 300-ohm ribbon feeder was connected to this element at the center, the other end being brought down to the operating position. A one-turn loop was connected to the end of the 300-ohm feeder to allow checking with a grid-dip meter. The element proved to be resonant at 14.2 MHz. Short extra lengths of 300-ohm feeder were added until resonance fell to 13.8 MHz, and a 500-pF variable capacitor was then connected in place of the loop as shown in Fig. 2. This allowed the

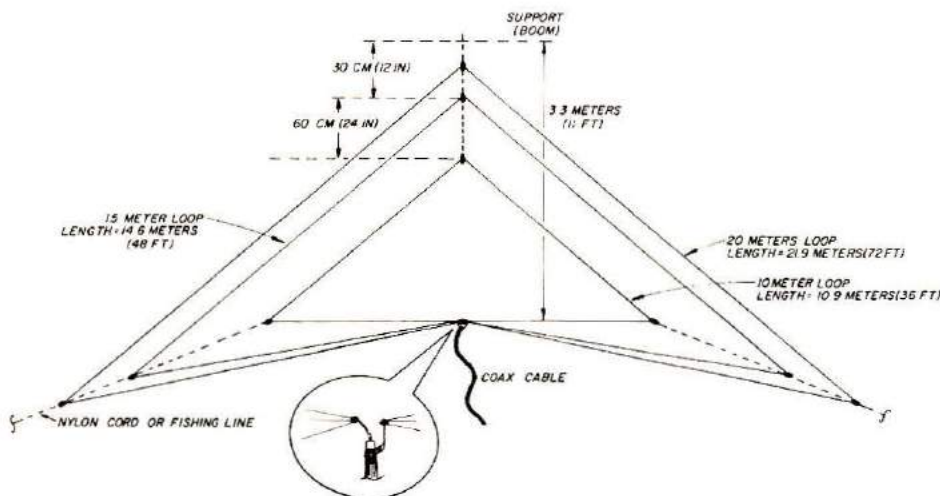

Fig. 1. Dimensions and mounting details for the driven elements of the delta-loop antenna. Loops of the same size can be used for reflector or detector if fed with twin-lead transmission line as described in the text. Nylon cord or fishing line is used to support the tops of the loops and to pull the bottom corners out to position. Lengths given for the loops are total length of wire around the loop.

resonant frequency to be altered.

This was it — would it work? Well, yes and no! A gain toward the U.S. of about one

element. The SWR was found to be almost completely unaffected by the tuning of the reflector, and so my conclusion was that the delta loops were

spacings of around 2.4 to 3.6 meters (8 to 12 feet) and it is not clear just why such close spacing is needed for the best results with my delta loop.

Fig. 3. The driven elements are in the same vertical plane, and fed in parallel as in Fig. 1. The parasitic elements are all mounted the same distance from the driven element at the top, but are staggered in distance from it at the bottom. The 20-meter elements are 1.8 meters (6 feet) apart at the bottom, and the 10-meter ones are 0.9 meters (3 feet) apart, with 15 meters halfway between. Separate twin-lead feeders are connected to the parasitic elements for each band. The balun is a few turns of coaxial cable wound through a ferrite core (see text).

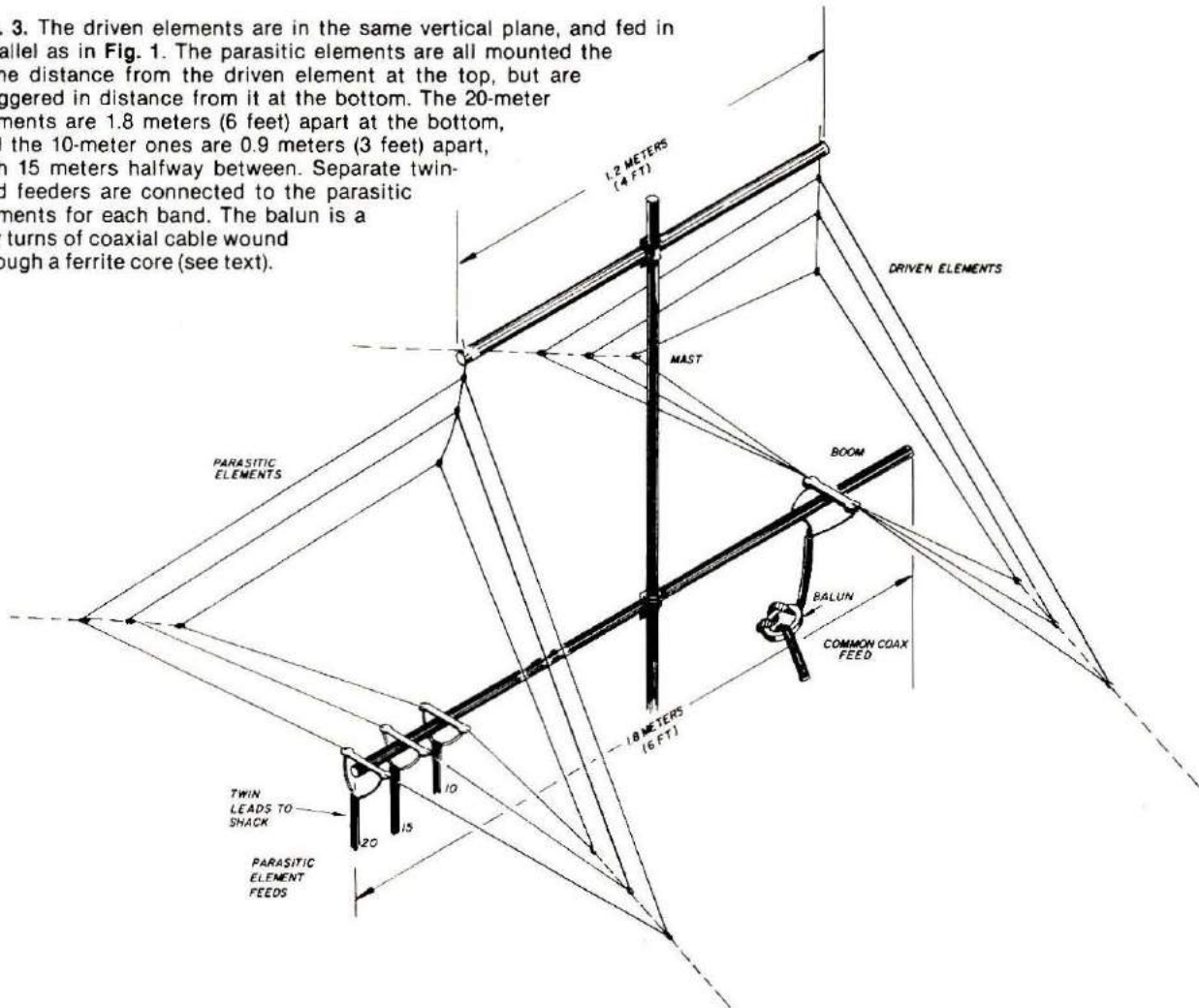

S-unit (over the delta loop on its own) occurred when the capacitor was set at anything above about 50 pF or so. The front-to-back ratio was very poor, adjustment of the capacitor was very broad, and the tuning very flat. Attempts to tune the reflector to act as a director were disappointing and produced no gain or front-to-back ratio at all.

At this point I decided to recheck the standing wave ratio, because adjustment of a parasitic element should normally have quite an effect on the impedance of the driven

too widely spaced. This was indeed the case, and, upon reducing the spacing to 1.8 meters (6 feet), things really started working. The front-to-back ratio increased dramatically. By altering the length of the feeder cable slightly and tuning the variable capacitor, I was able to fire the beam east or west, although with somewhat less gain when the reflector was tuned as a director. The SWR was also quite sensitive to the tuning and could be brought down to around 1 to 1.

Normal quads and delta loops for 20 meters use

Perhaps the following points are worth thinking about, however:

1. Most measurements of quads and delta loops are made on vhf scale models which are mounted several wavelengths in the clear; the presence of the roof could be affecting results.
2. The thickness-to-length ratio of the vhf antenna elements is likely to be very much different from that of a high-frequency antenna even if wire, rather than tubular elements, is used.

3. Having the tuning control in the shack enables instant reversals to be made, and hence the merits or faults of the antenna are more readily noticed. A spacing of 1.8 meters (6 feet) gave the best results, so whatever the textbooks say, and whatever the reason, this it remains!

Next, a 15-meter reflector was added and connected to the same 300-ohm feeder, which, on 15 meters, was $1\frac{1}{2}$ wavelengths long. This was not a success, and while slight gain and front-to-back ratio resulted, the tuning was poor and indecisive. Also, 20-meter operation suffered. Hence, it was found necessary to use a separate 300-ohm feed for each band.

The final design

Ideally, the elements should be spaced at 0.9, 1.3, and 1.8 meters (3, 4, 5, and 6 feet) respectively, at the top as well as the bottom, but the arrangement shown in Fig. 3 is mechanically convenient and works well. The feeder from the driven element can be any good quality 75- or 50-ohm twin or coaxial feeder. The feeder from the reflector should be open wire or TV-type ladder feeder, but 300-ohm ribbon works quite well unless you reside in a very damp climate. Be sure that the parasitic-elements feeder is kept well away from any metal objects, and, if possible, mount it on stand-off insulators. The electrical length of a half wavelength is approximately $5\frac{1}{2}$, 7, and 11 meters (18, 24, and 36 feet) on the three bands, and open wire or ladder feeder should be cut to a multiple of this: for instance, 21.9 meters (72 feet), which equals 2×36 , 3×24 , and 4×18 feet. This is a suitable length for all bands. 300-ohm ribbon feeder has a velocity factor of around 0.8, and so a length of about 17.6 meters (58 feet) is suitable. When you have decided on the

length of parasitic feeder, add about 1.2 meters (4 feet) to the 20-meter feeder, 0.9 meter (3-foot) to the 15-meter feeder, and 0.6 meter (2 feet) to the 10-meter feeder, so as to bring the element and feeder resonant as a reflector when the tuning capacitor is set at maximum.

Trying it out

First of all, test the driven element by measuring the SWR. If the elements have previously been trimmed and adjusted by a grid-dip meter the SWR should measure around 2 to 1.* The SWR will vary somewhat as you tune across the band, but if it goes above 3 to 1 and is much worse at one end of the band than the other, it will be necessary to adjust the length of the driven element to even out the response.

Once you have the driven elements working, install the parasitic elements. For convenience of construction, parasitic elements can be made the same size as the driven element, there being no need to adjust it exactly to frequency, as this will be done later from the operating position.

Next, bring all the feeders into the shack, and put one-turn loops on the end of the tuned feeders going to the three parasitic elements. Check, with a grid-dip meter, the resonant frequencies of the parasitic elements plus tuned feeders. There will be quite a number of resonant points, but main resonances should occur approximately 100-200 kHz below the lower end of each of the bands. If necessary, adjust the length of the open wire feeder until this occurs. Note that grid-dip meters are not usually accurately calibrated, and so the frequency should be checked against a frequency

*Connect a one-turn coil instead of the feeder to measure resonant frequency. You can only do this on the roof; you cannot grid-dip the driven element frequency at the end of the feeder.

meter, or monitored on an accurately calibrated receiver.

Having done all this you are in business. Leave the coils in place and you have a three-

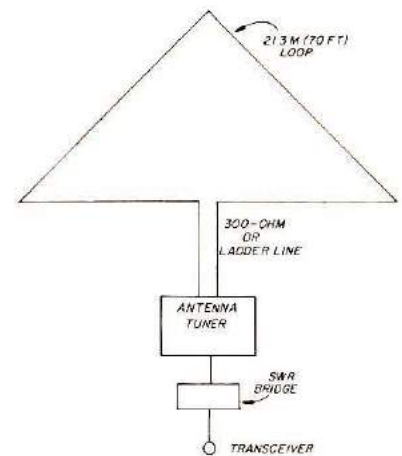

Fig. 4. A single loop can be made to work on three bands and fed with one feedline if you use a tuner and open wire line. It also works to some extent on 40 meters. It's a good substitute for a trap dipole.

band beam which will give good results in your favored direction. Disconnect the loops and wire in a variable capacitor of approximately 500 pF maximum, and the beam becomes reversible. If you measure the SWR you should find that maximum forward gain and front-to-back ratio, with the parasitic element acting as a reflector, occurs with the variable capacitor set very slightly toward the maximum capacitance side from that which gives minimum SWR. Maximum forward gain in the opposite direction occurs with the capacitor near minimum, and in my case results in an SWR of about 1.75 to 1.

Front-to-back ratio is about 3 or 4 S-units on local ground-wave stations, and on stations several thousand miles away. The gain under these conditions is $1\frac{1}{2}$ to 2 S-units when operating a director. Directivity on stations less than a thousand miles away varies greatly with conditions, and can be as good as that indicated above or almost non-existent if reception

R-X Noise Bridge

All Palomar Engineers products are made in U.S.A. Since 1965, manufacturers of Amateur Radio equipment only.



- Learn the truth about your antenna.
- Find its resonant frequency.
- Adjust it to your operating frequency quickly and easily.

If there is one place in your station where you cannot risk uncertain results it is in your antenna.

The Palomar Engineers R-X Noise Bridge tells you if your antenna is resonant or not and, if it is not, whether it is too long or too short. All this in one measurement reading. And it works just as well with ham-band-only receivers as with general coverage equipment because it gives perfect null readings even when the antenna is not resonant. It gives resistance and reactance readings on dipoles, inverted Vees, quads, beams multiband trap dipoles and verticals. No station is complete without this up-to-date instrument.

Why work in the dark? Your SWR meter or your resistance noise bridge tells you only half the story. Get the instrument that really works, the Palomar Engineers R-X Noise Bridge. Use it to check your antennas from 1 to 100 MHz. And use it in your shack to adjust resonant frequencies of both series and parallel tuned circuits. Works better than a dip meter and costs a lot less. Send for our free brochure.

The price is \$49.95 in the U.S. and Canada. Add \$2.00 shipping/handling. California residents add sales tax.

Fully guaranteed by the originator of the R-X Noise Bridge. ORDER YOURS NOW!

Palomar Engineers

Box 455, Escondido, CA. 92025 • Phone: [714] 747-3343

is by high angle radiation. This fact of life applies to all beams.

A simple version

During construction and testing of this antenna, the effect of using one 20-meter element as a multiband delta loop on 10, 15, and 20 meters was tried; it proved most effective. Directivity on 20 and 15 meters is the typical figure-eight pattern while as far as could be ascertained, good results on 10-meters short skip in all directions occurred. This arrangement is shown in Fig. 4, and can be highly recommended to anyone wanting good results for minimum effort.

Final notes

Signal fading makes it almost impossible to evaluate antennas over long paths by the usual method of making contact and asking for reports. If you doubt this, ask any station for comparative reports between "my old antenna" and "my new antenna," giving them two transmissions on the same antenna. Most stations will tell you that "the new antenna" is better — if you don't believe me, try it!

Resonant antennas should perform exactly the same whether receiving or transmitting, and should give the same gain in either mode. Comparative tests with antennas should be done in the receive mode, as this enables the test to be repeated and comparisons made with many stations. Tests carried out with only one or two stations can produce misleading results, as it is the average results that really matter and not what happens with a particular station under a particular set of conditions. Only after months of operations do the full merits of an antenna become clear — I can only say that I am delighted with the low-cost, reversible delta loop. If you hear me, give me a shout.

HRH

The Larsen Kūlrod® Antenna

Good Looker...

Great Performer

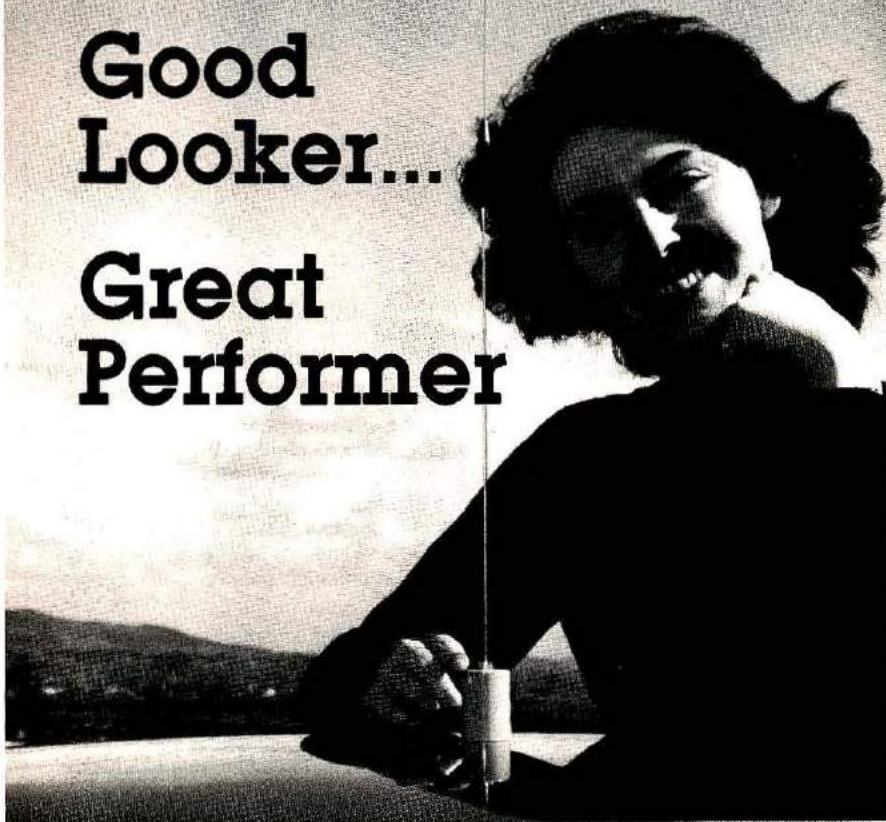

They say "beauty is as beauty does". And the streamlined, low silhouette Larsen Kūlrod Antenna performs as beautifully as it looks!

You get real performance, thanks to solid contacts with no power wasted in inefficient base or phasing coils. And there's no power loss through inefficient high loss whips when you use a Larsen Kūlrod Antenna.

These antennas were engineered to serve the tough, highly competitive two-way communications field. They are in demand and sold throughout the United States and around the world — though often priced a bit above other antennas. The reason? Top performance and looks.

Larsen Kūlrod Antennas are available at leading Amateur stores. Choose from a variety of easy-to-install permanent and temporary mounts in the 50, 144, 220 and 440 MHz amateur frequencies.

Write for a free catalog and name of the nearest Larsen dealer. And before long you'll be getting "fine signal" reports on your new Larsen Kūlrod.



Larsen Antennas

You can HEAR the difference!

11611 N.E. 50th Ave. / P.O. Box 1686
Vancouver, WA 98663 / Phone: 206/573-2722

In Canada write to: Unit 101 - 283 E. 11th Avenue
Vancouver, B.C. V5T 2C4 / Phone: 604/872-8517

*Kūlrod is a Registered Trademark of Larsen Electronics, Inc.



FUN

**New friends,
New horizons,
and New challenges.
Enjoy life with
ham radio.**



Here, in one easy-to-read fully illustrated book, you will find everything you need to know to get an amateur license and assemble and operate your ham station. The package also contains a workbook with sample questions, and a cassette tape that is an easy step-by-step guide to the Morse code. Get the complete *Tune In The World With Ham Radio* package at your favorite dealer or direct from ARRL. Just \$7.00 USA, postpaid.

Enclosed is \$_____ or charge my () VISA () Master Charge for the TUNE IN THE WORLD WITH HAM RADIO package.

NAME _____

ADDRESS _____

CITY _____

STATE _____

ZIP _____

VISA/MC Number _____

MC Bank _____

Expiration _____



AMERICAN RADIO
RELAY LEAGUE
225 Main Street
Newington, CT 06111

 **target**
your signal
with a
Ham IV
rotor

*the Engineered
Choice for
Antennas Up
to 15.0
Sq. Ft.*



The New HAM IV — just one of six rotors from CDE to professionally target your signal for better communications . . . exclusive features like all-steel gear systems and positive power brake make the HAM IV the newest standard by which all other rotors are judged.

ON TARGET KIT

Send for your EMBROIDERED PATCH, WALL CERTIFICATE, TIME ZONE GUIDE. Plus details on the CDE Rotor to match your antenna. Enclose \$1 for handling and mailing costs. Send to:



CDE CORNELL-DUBILIER
CORNELL-DUBILIER ELECTRIC CORPORATION
Box 162, Essex Fells, New Jersey 07021 358R

I'm On Target—Send Kit To: H4

Name _____

Address _____

City _____

State _____ Zip _____

- Enclosed \$1. for kit handling & mailing.
or
 Send free details on all CDE rotors.

New! Two full watts output!
Throw rocks on 40 or 80 for \$25.95*



only
\$25.95

Kantronics Rockhound transmitter

Jump into QRP!

The **Kantronics Rockhound QRP transmitter** now generates a two-watt CW signal anywhere on 40 or 80 meters, depending on your model choice. With the right crystal and a little luck, Granite Falls, MI is just a stone's throw from Boulder, CO.

Slip the Rockhound into your pocket for mountain hikes or camping trips. It's only 3½" by 4" by 1½"! Our 8040-C receiver makes a lightweight companion. For power, just hook 12-15 Vdc in line with your key. A simple dipole puts your **Rockhound** on the air!

Start throwing today, our address is below.

* \$29.90 with crystal. 7.125 or 3.725 MHz available.

KANTRONICS

The Lightweight Champs.

1202 East 23rd Street
Lawrence, Kansas 66044

We accept Visa, Master Charge, check and money orders.

Phone: 913-842-7745

**Twice as much
for less.**



HRB's new LOG BOOK is here — and it is unquestionably the finest one you'll ever use. 80 big, **double-sided** pages of clear, legibly ruled stock, all spiralbound to lie flat for easy writing. More than 2000 entries give you twice the space for less money than the log book you are probably using now. Order yours today! 8-3/8" x 10-7/8", 80 pages.

ONLY \$1.75 each (plus \$1.00 shipping)

Order 3 or more logs and we'll ship postpaid.



Send check or money order to:

HAM RADIO'S BOOKSTORE
Greenville, NH 03048

STEP UP TO TELREX

Professionally Engineered Antenna Systems

Single transmission line "TRI-BAND" ARRAY

"MONARCH" 10, 15, 20 Meter
Model TB5EM/4KWP

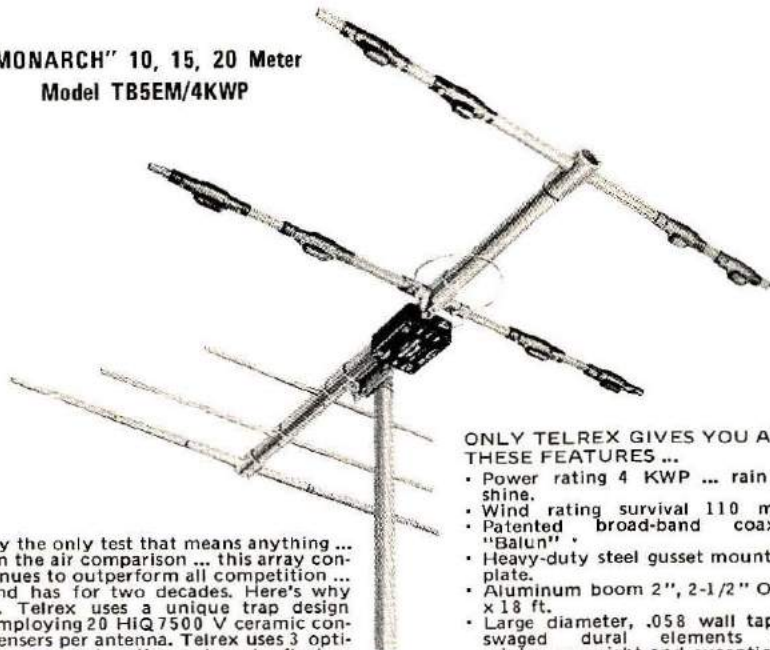

By the only test that means anything ... on the air comparison ... this array continues to outperform all competition ... and has for two decades. Here's why ... Telrex uses a unique trap design employing 20 HiQ 7500 V ceramic condensers per antenna. Telrex uses 3 optimum-spaced, optimum-tuned reflectors to provide maximum gain and true F/B Tri-Band performance.

ONLY TELREX GIVES YOU ALL THESE FEATURES ...

- Power rating 4 KWP ... rain or shine.
- Wind rating survival 110 mph
- Patented broad-band coaxial "Balun"
- Heavy-duty steel gusset mounting plate.
- Aluminum boom 2", 2-1/2" O.D. x 18 ft.
- Large diameter, .058 wall taper-swaged dural elements for minimum weight and exceptional strength to weight ratio.
- Stainless steel electrical hardware.

At 50 ft. or more (above ground) a rugged Telrex "Tri-Band" is the only answer to longevity ... a true money saver.

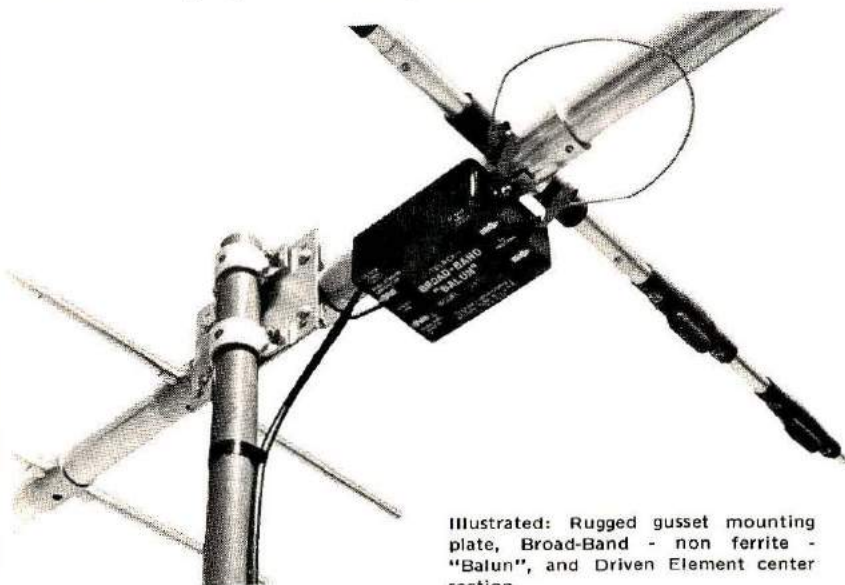

Illustrated: Rugged gusset mounting plate, Broad-Band - non ferrite - "Balun", and Driven Element center section.

For technical data and prices on complete Telrex line, write for Catalog PL-7.

TV and Communications Antennas Since 1921

telrex LABORATORIES

P.O. Box 879 - Asbury Park, New Jersey 07712

Phone 201-775-7252

RADIO AMATEUR CALLBOOKS FOR 1979



Respected worldwide as the only complete authority for radio amateur QSL and QTH information

The U. S. Callbook has nearly 350,000 W & K listings. It lists calls, license classes, names and addresses plus the many valuable back-up charts and references you come to expect from the Callbook.

Specialize in DX? Then you're looking for the Foreign Callbook with almost 285,000 calls, names and addresses of amateurs outside of the USA.

U.S. Callbook \$15.95

Foreign Callbook \$14.95

(Plus Shipping)

Order from your favorite electronics dealer or direct from the publisher. All direct orders add \$1.75 for shipping. Illinois residents add 5% Sales Tax.

RADIO AMATEUR **callbook** INC.
Dept. E 925 Sherwood Drive
Lake Bluff, Ill. 60044

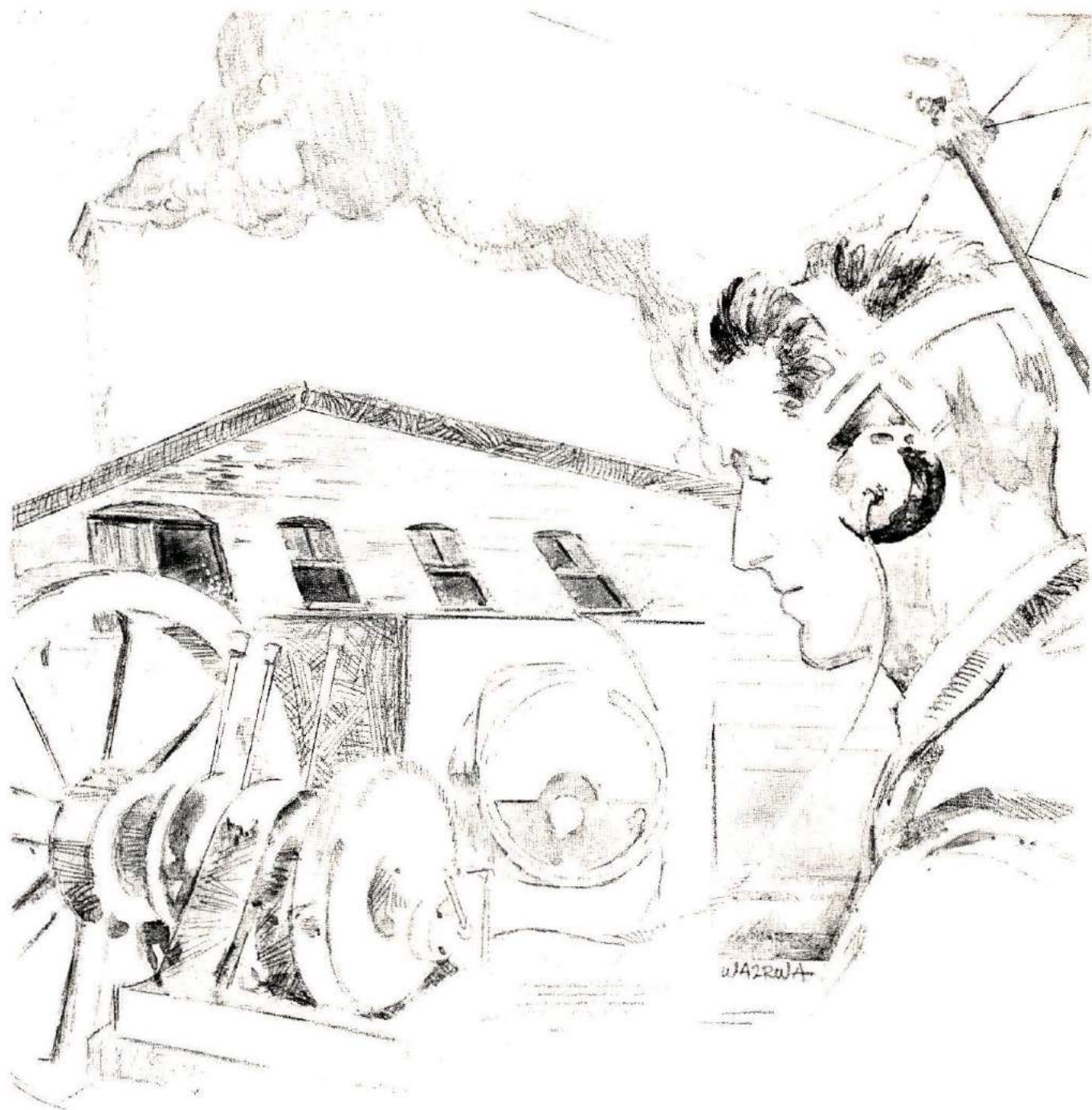

Tales of Old Wireless

BY ALAN S. DOUGLAS

Author's preface: This is really Harold Mansfield's story. I've known Harold Mansfield about eight years, just a fraction of the time he's been involved in radio. Harold has a wealth of stories to tell, and I decided to set down on paper a few of them — stories that have historical interest and capture the flavor of days when hams roamed the airwaves unlicensed.

Harold Mansfield's Story

Many have heard the account of Nikola Tesla causing the Colorado power station to be shut down by drawing too much power for his experiments.* On a smaller scale, I once did nearly the same thing in Plymouth, Massachusetts. After 1910 I worked for the Plymouth Electric Light Company, whose plant was on Leyden Street on the waterfront (the buildings were removed in 1920 for the Tercentenary celebration to "improve the atmosphere" of Plymouth's oldest and most historic street). I was in high school and worked from 2 to 9 PM testing meters in a room above the stock room, across the street from the main plant. After the regular repairmen went home for the evening, I was also on call to repair street lamps and such.

An early ham station

A friend and I had often snooped around the Brant Rock wireless station a few miles away, where the most advanced work was going on in those days. By watching through an

Nikola Tesla's electrical observatory in Colorado in 1899. The setup was used to test a huge Tesla coil. Power drain on local facilities was too much; the electrical generator burned out.

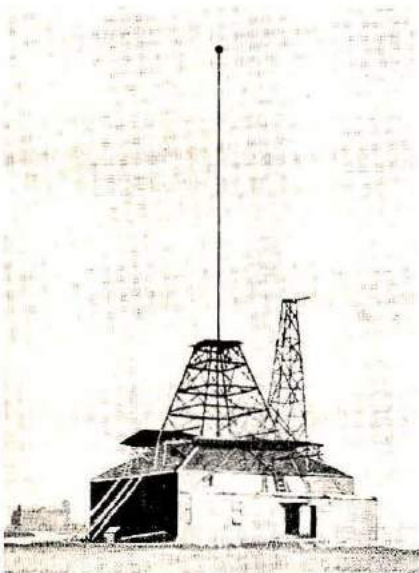

The Plymouth, Massachusetts, power station as it appeared between 1910 and 1920.

open door with a telescope, we had discovered the rotary spark gap responsible for the high-pitched tone characteristic of this station.

I had my own wireless station above the electric company's stockroom. Through friendship with Spink Donlavy, the Brant Rock tower man, I obtained a 2-kW General Electric open-core high-voltage transformer when the Plymouth test station was dismantled and the equipment was returned to Brant Rock in 1911. This monster stood two feet high and was enclosed in red fiber with insulators on top. I built a 20-tooth rotary spark gap, copied from a Clapp-Eastham design. The condenser† was made with 1/4-inch glass plates salvaged from the base of the Brant Rock tower. These plates were two feet square. I cut them in half and cemented tinfoil to them with collodion, then I painted the outer edges with asphaltum to inhibit corona discharge.

*On July 3, 1899 the first full-power test of a gigantic Tesla coil, capable of throwing 100-foot lightning bolts, drew so much current that the generator at the power station burned out.

†For newcomers, a capacitor was called a "condenser" in the old days. Same horse with a different name. That's progress.

Editor

The stockroom building was long and narrow, ideal for a six-wire flattop antenna above the roof. Energy for the stockroom lights was supplied by a husky pole transformer across the street in front of the power plant, so I had no fears of an inadequate power source for my 2-kW rig. (What I didn't know was that the same transformer supplied the Tirrill regulator that controlled the output voltage of the whole plant.) This regulator, beautifully built into a glass case, controlled the field current of two 360-kW alternators.

The moment of truth

At 4 PM I made the last connection, turned on the rotary gap motor, and pressed the Massie key just once. When the lights nearly went out, I knew something was wrong. Moments later the downstairs door flew open and in burst the manager, Mr. Eugene Perry Rowell.

"What are you doin' up there? You almost shut down the town!"

A kickback (rf in the power line) had fused the Tirrill regulator contacts, and the

Rigger Donlavy atop one of the pipe masts supporting the flat-top portion of the Brant Rock antenna.

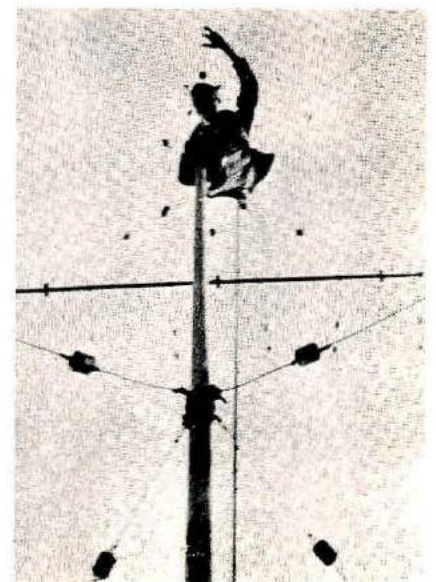

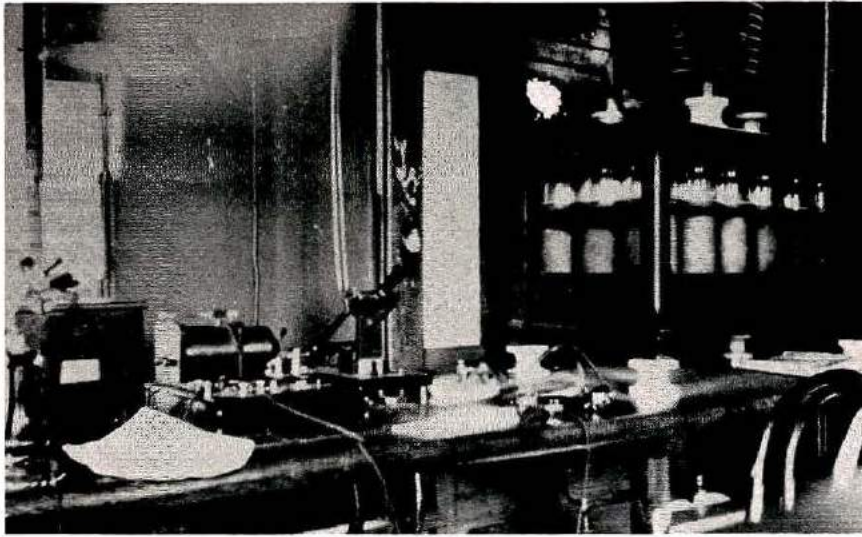

Mansfield's wireless station (ca. 1912). Equipment was constantly changing. At this point a bank of Leyden jars was used for rectifiers, which had been obtained from Walter Massie.

men said they'd never heard such a growling noise come from the alternators. It scared the daylight out of them.

Said Mr. Rowell, "You clean this place out. There'll be no more wireless around here!" It's a good thing I'd been teaching his son electrical theory or I'd have been fired on the spot.

About that time (1912) a new radio law had been passed,

which required licenses, and imposed limits on wavelength and power. The whole idea of licensing went against my grain, and I just let the matter drop.

A visit to an early manufacturer

The Massie Wireless Telegraph Company of Providence, Rhode Island, was active from 1905 to 1912,

A 1906 Massie Oscillaphone detector, which was reconstructed from a few original parts in 1978. The actual detector is a sewing needle laid across two carbon knife edges. It was crude but workable, better than a coherer detector, and free from patent infringements. Crystal detectors had not yet been invented. Compare this with one of your solid-state diodes in your junkbox.

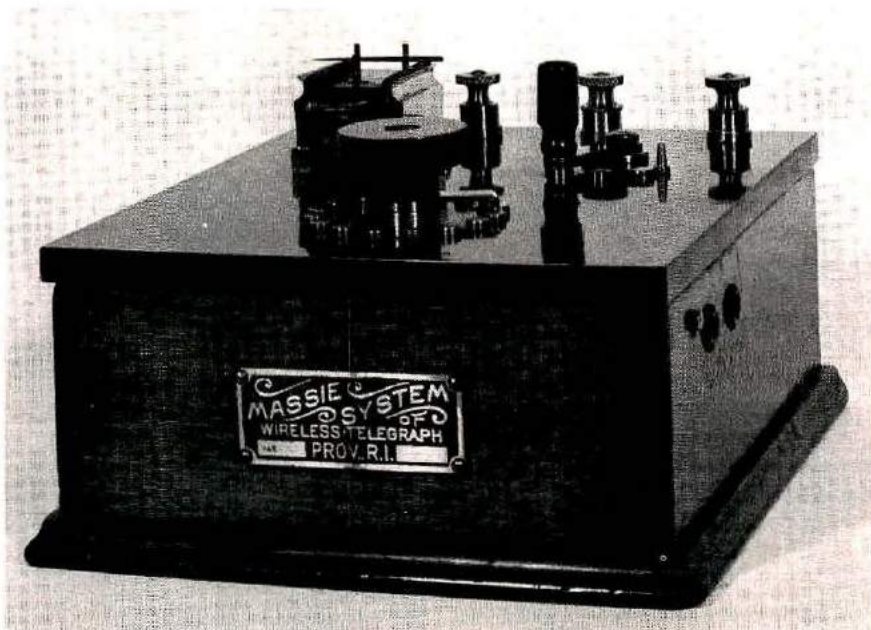

equipping the Fall River line and other passenger ships as well as Navy stations on the east and west coasts.

About 1911 I saw a Massie advertisement. Not knowing anything about them, but thinking it would be a fine place to buy a 25-cent resistor or some other part I needed, I took a train there one Saturday morning. I located the shop, on Market Square near the State House, on the second floor. I walked in and oh boy —

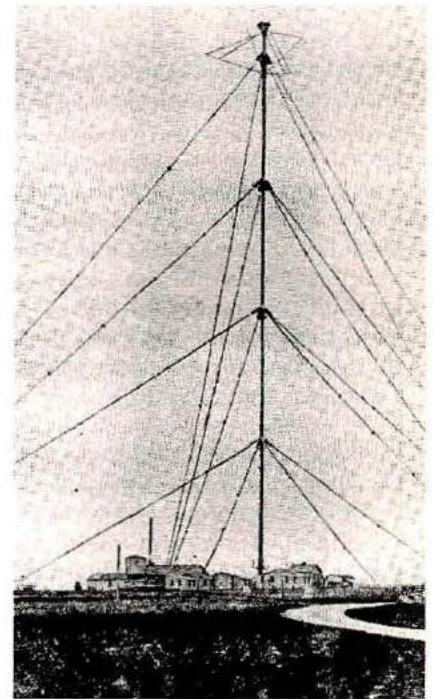

View of the antenna at the Fessenden wireless station at Brant Rock, near Plymouth, Massachusetts.

second heaven! Machine tools everywhere. Men working busily turning out Massie wireless sets. The whole room hummed with activity.

A nearby man looked up from his machine to see what had come in the door, then came over to find out what I wanted. I told him I came to buy a resistor (or whatever it was). He laughed and asked me what I wanted it for. We started talking about electricity and wireless. As we stood there I could see his eyes shifting, as if someone were behind me. I turned around and another man took over with more questions:

"Where did you learn all this wireless stuff?"

I told him there was a big station near me, the Fessenden station at Brant Rock, and I hung around the place. His eyes really lit up then and he began asking me more and more details about the Brant Rock operation for over an hour.

I thought this was an odd electrical store — *he* was asking *me* all the questions — and I still didn't have my resistor!

Come to find out, it was Walter W. Massie himself, and he was pumping me for information on his competitor! Well, from that time on the shop was mine — "Come in any time, stay as long as you want." Every Saturday for an entire summer I took the train to Providence.

One way to obtain equipment

Several months later I received a letter from Massie. He was selling out to the American Marconi Company,

The Harris-Corliss steam engine, which powered electrical alternators, is located in the New England Wireless and Steam Museum, East Greenwich, Rhode Island. It is almost identical to the steam engines installed at Plymouth, Massachusetts, at the Brant Rock station around 1910.

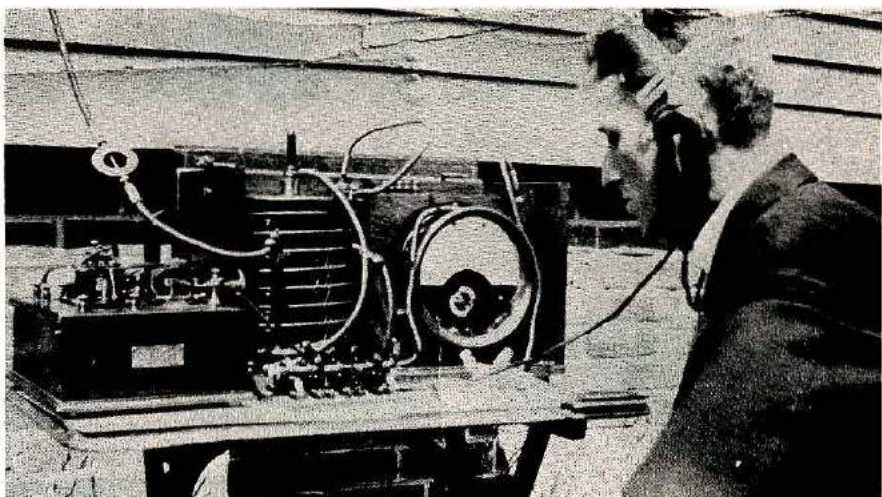
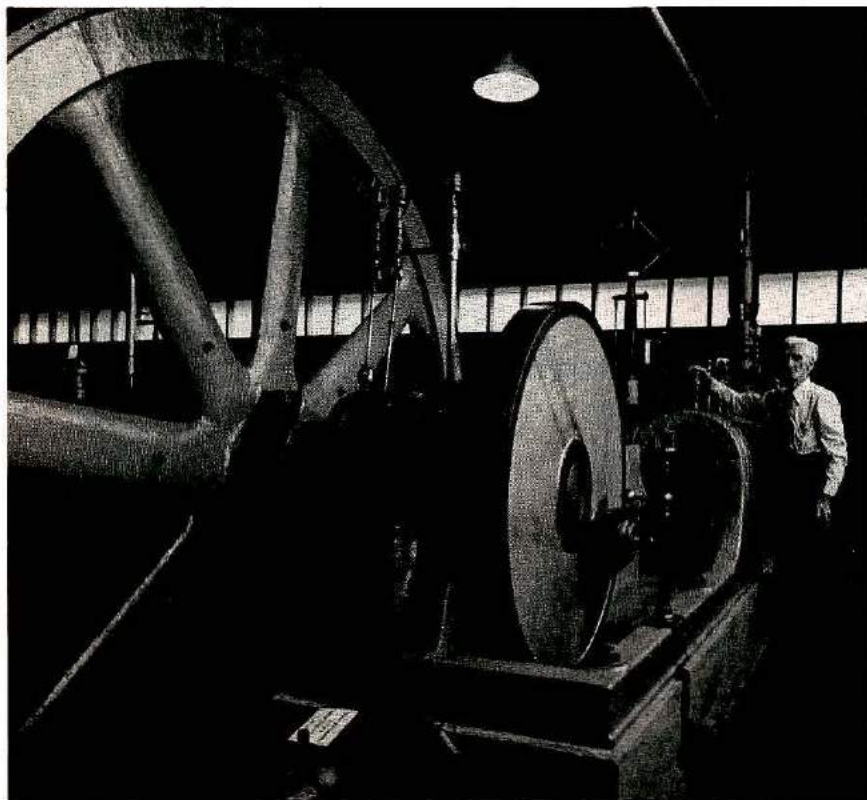

A Massie portable wireless set designed for the U.S. Army Signal Corps in the early 1900s.

and if I wanted anything at all from the shop, he would give me a good price. I brought back a big truckload of stuff: keys, meters, Oscillaphone detector boxes and receivers, a Fleming Cymometer wavemeter, complete transmitters — even a box of Massie and Underhill wireless textbooks.

Most of this gear was later

scrapped; some was resold through the years. One key, an antenna changeover switch, and a reconstructed detector box survive today. The ivory scale of the Fleming wavemeter went to the Smithsonian Institute in 1932, where, the last I heard, it rests under glass.

The view from here

Climbing the Brant Rock tower was quite an experience. The tower was made of steel tubing with a ladder inside. It consisted of four 100-foot sections plus 20 feet at the top. A platform was installed every 100 feet where the guys attached.

The view from the top was spectacular, but no one was allowed near the place. Even after the station was abandoned in 1912, the grounds were patrolled by a watchman.

However, a friend and I sneaked in one Sunday when the watchman was elsewhere and made our way to the top. That was fine. But the watchman returned and we couldn't get down! We had to wait until dark. By then, the streetcars had stopped running and I had to walk 10 miles back to Plymouth. And it rained. And I got home at half past two in the morning. But what an experience!

HRH

Call **Toll Free** 1-800-243-7765

FREE

- Retail Price Catalog
- Monthly Computerized Used Equipment List
- Courteous, Personalized Service



KENWOOD TS-820S



YAESU FT-901

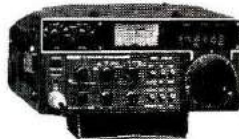

ICOM IC-701



KDK 2016A



CUSHCRAFT ANTENNAS

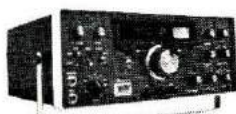

TEN TEC OMNI-D

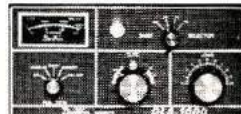

GLA-1000



CPU 2500 R/K

OVER 50 BRANDS IN STOCK

- KENWOOD • SWAN • KDK • DENTRON •
- MOSLEY • WILSON • YAESU • DRAKE •
- LARSEN • BENCHER • PIPO • BEARCAT •
- B & W • DATONG • ICOM • PANASONIC •
- ARRL PUBLICATIONS • ALLIANCE • MFJ •
- CUSHCRAFT • TRAC • MICROLOG • CDE •
- FINCO • DSI • DAYBURN INSULATORS •
- BIRD • ASTATIC • HAM KEY • REGENCY •
- HUSTLER • SAXTON • TEN TEC • AMECO •
- AMCOMM • CALL BOOK • KLM • TEMPO •
- ATLAS • ALDA • COVERCRAFT • HY-GAIN •
- J.W. MILLER • MURCH • PFENTONE •
- SHURE • TAB BOOKS • SAMS BOOKS •
- ROHN • BUTTERNUT • Plus Many More!

- ★ NEW AND USED EQUIPMENT
"Get on our used equipment mailing list"
- ★ TRADES WELCOME
"The best allowances anywhere"
"We buy good used SSB gear"
- ★ FREE CATALOG
"Prices of all major manufacturers"
- ★ SAME DAY U.P.S. SHIPPING
"Just a phone call away"
- ★ COMPLETE RADIO SERVICE SHOP
"Mail Order Repair Service"

- Fast Efficient Service • We Repair All Brands
- All Work Guaranteed • Amateur Extra/First Class Licenses • Send Us Your Defective Equipment U.P.S. Collect • Please Include Manual and Power Supply
- Free Shipping Both Ways If Work Is Done
- Most Repairs Done and Shipped Within 7 Days

OUR FINE REPUTATION SPEAKS FOR ITSELF

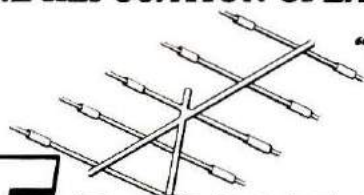

**"YOU SHIP IT
WE FIX IT"**

THOMAS COMMUNICATIONS

95 Kitts Lane, Newington, Conn. 06111

"Near ARRL Headquarters"

**Call
or Write
for your
super quote
today!**

Connecticut Residents Call:

(203) 667-0811



OPEN MON.-FRI. 10-6 • THURS. 10-8 P.M. • SAT. 10-4

EASY DIRECTIONS: Rt. 15 South — 2 blocks past McDonald's
(Berlin Turnpike)

A Look at

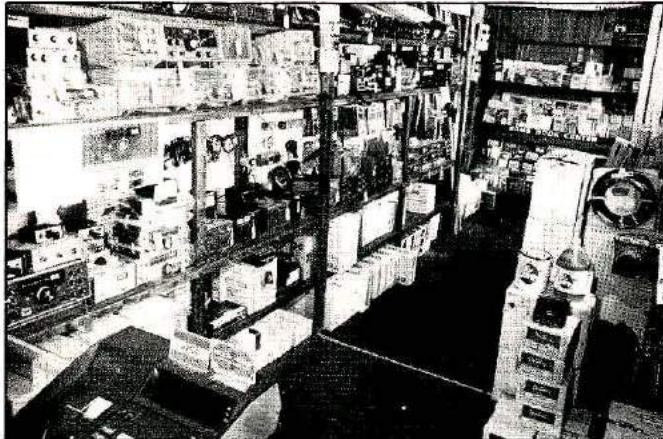

New Equipment — All new equipment on display is operating for actual "on the air" QSO's. We really know our gear!



Used Equipment — We recondition and guarantee all our used equipment. We make sure it satisfies you!



Service Shop — You've probably heard of our fine service reputation — using Cushman CE4B signal generators, Hewlett Packard oscilloscopes, Bird wattmeters — we fix it right!



Inventory Warehouse — Our large volume assures you the best prices!

**And Our Service Is Even Better!
Give Us a Call and See
For Yourself!**



1-800-243-7765



95 Kitts Lane, Newington, Conn. 06111
(203) 667-0811

Swan's Success Story:

100MX Power House

The Field-Proven Rig the Whole World's Talking About.

235 Watt PEP
and CW on
ALL Bands

Price? You won't
believe it! Just ask
your dealer.

All solid state quality American
construction, with epoxy glass
boards to withstand the
rugged mobile environment.



Look to Swan for Quality Accessories . . . and Service



SWAN
ELECTRONICS

A member of the Cubic Corporation family of companies.

305 Airport Road
Oceanside, CA 92054
714-757-7525

A Knob with a new twist "VRS™"

Swan Astro 150 Exclusive Microprocessor Control w/memory gives you over 100,000 fully synthesized frequencies, and more!

- VRS — Variable Rate Scanning, a dramatic new technique for unprecedented tuning ease and accuracy
- POWER — 235 watts PEP and CW on all bands for that DX punch
- Advanced microcomputer technology developed and manufactured in the U.S.A.
- Price? See your authorized SWAN dealer for a pleasant surprise!

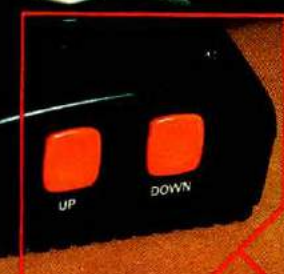

Dual Meter
Reads PEP output in watts and receive "S" units.

Full Break-in CW
(or semi, switch selected)

Wide Frequency Coverage

- 10M — 28.0-30.0 MHz
 - 15M — 20.8-23.0 MHz
 - 20M — 13.8-16.0 MHz
 - 40M — 6.0-8.3 MHz
 - 80M — 3.0-4.5 MHz
 - 160M — 1.8-2.4 MHz*
- *in lieu of 10M band on Model Astro 151

Mike Tuning
For accurate 100 Hz steps or fixed rate scan.

PSU-5
Power Supply
with Speaker



THE MOST ADVANCED HF SSB TRANSCEIVER AVAILABLE.

FULLY SOLID-STATE **SWAN ASTRO 150**

SWAN
ELECTRONICS

A member of the Cubic Corporation family of companies.

305 Airport Road / Oceanside, CA 92054 / 714-757-7525



Dear Horizons:

While thumbing through some back issues of *Ham Radio Horizons*, I decided to build up the one-transistor rig for 40 meters described in the April, 1978, issue.

After completing the breadboard arrangement, my first CQ raised a response from W4BFQ in Merritt Island (across the bay from Cape Canaveral). He reported RST 589! Next morning, out with the dawn patrol, I called W7LO and received a RST 549 from Phoenix, Arizona. That's my best DX. Other stations in south Florida are worked with ease. Instead of the 2N3553, I used the Motorola MPS-U05, which can be obtained from Heathkit. It is used in the Heathkit QRP rig, HW-7. Keep those little projects coming — they are what we "weekend engineers" need.

Phil Partee, W4ABI
Miami, Florida

Dear Horizons:

I'm pleased to advise you that three weeks ago I passed the Canadian ham radio operator exam, and my new call sign is VE7CSX.

Your magazine helped me a great deal in my studies — keep up the good work. I like *Ham Radio Horizons* because it is designed for us beginners.

G. Horvath, VE7CSX
Port Coquitlam, British Columbia

Dear Horizons:

I am writing this note to tell you just how great your Publishing Group is. I have been fighting for two years to get books for ham classes . . . this last six months I struck gold with you. Fast, prompt, and efficient service. Thank you.

Next, I want to thank you for running the ad for the Oak Hill Academy Radio session. I flew

back there this summer, and returned to Germany in time to help four Novices upgrade in September. Mr. Carl Peters puts into two weeks what most clubs take two years to cover!

John C. Kaskell, DA1UY/KA1CZ

Dear Horizons:

I greatly enjoyed your article on how to be a lid; but unfortunately you missed two of my favorite lidisms.

How about the big-time experimenter who ties up some good DX station for 15 minutes while he twitches the switches on his speech processor and says "ah."

Also, how about the two yoyos, who, after finding that they each have 20-dB-over-9 signals when running barefoot, (low power), go right back to their 2 kW's.

I disagree with the author's premise that all "Q" signals belong on CW alone, since many of them have been there as long as "DX." It does, however, give me the dry heaves to hear some guy on ssb talking about warm "WX." 73rds.

Bill Robinson, W5QAR
Rockport, Texas

Thanks for your comments, Bill. We've received several letters about the "lidisms," some applauding us, some giving us the raspberry, but all interesting. From the tone of the letters it is obvious that A, the authors only scratched the surface of lidisms, B, some people whose toes were stepped on have no sense of humor, and C, there are as many opinions about operating procedure as there are amateurs. Keep the Aika-Seltzer handy. Editor

Dear Horizons:

To add to the article in October, 1978, *Ham Radio Horizons*, by K4QF about visiting hams, I would like to give some information for hams visiting Europe. In Europe we have ten repeater channels on two meters; R0 — R9 with input frequencies from 145.0 to 145.225 and output frequencies 145.6 to 145.825 MHz. Most European repeaters can be opened with a 1750 Hz audio tone. There are no private or closed repeaters in Europe, and there are no autopatches. In addition to repeaters, there is also much

activity on simplex channels near 145.5. These are, (especially in Holland) 145.250, 145.275, 145.325, 145.350, 145.375, and 145.400 MHz. These are the channels where stations with a PD0 prefix are allowed to operate.

I hope this will be of some help to hams who wish to visit Europe.

Gabri Hoek, PE1CHF

Dear Horizons:

More thanks than there are frequencies go to a true ham, Jay Malay, WD8MET, who took a mixed group of people interested in radio and produced eight Novices. When the high school closed for summer vacation, before our educational session was over, Jay took this group of eight people into his home once a week. He also gave individual assistance at all times — his door was always open, which was the reason all got their licenses. Jay, true to his amateur status, would take no compensation as our instructor. He wanted us all to pass as his only reward, and we did!

Paul McFarland, KA8BXW
Allegan, Michigan

Dear Horizons:

I enjoy your magazine and without it I don't think I ever would have passed my test for my Novice license. I would like to get my father interested in ham radio. Would you please send me your information on becoming a ham for my father.

Also, if possible, would you please print an article on the construction of a 40-meter receiver. I'm building the 40-meter transmitter in your April 1978 issue. Keep up the good work.

Fred German IV, WA2OJU
Woodville, Alabama

We're glad to help your father become interested in Amateur Radio, Fred. Perhaps you have seen the 80/40-meter receiver in our February and March, 1979, issues, and the converter for higher bands in April. It was being designed when your letter arrived. Because of the variety of circuits involved in a receiver, there is no way to make one as simple (and effective) as the one-transistor transmitter, but I think author/designer Wildenheim did a great job in keeping it as plain as possible, yet obtaining great performance from it. Thanks for writing. Editor

Go Mobile With Our New 5-Band Rig.

A Good Buy At \$595.



A Little Midnight Oil. Our technical people stayed up nights fitting 5 bands into our standard model 103 chassis. The result is the Alda 105. It's a marvel of engineering. And now it's ready for you to enjoy.

Companionship on the Road. You'll have the power to stay in touch wherever you go. 250 watts PEP or dc input on 80, 40 and 20, 200 watts on 15 and 10 meters.

The ultra-stable VFO and solid-state, broadbanded final make mobile operation a real pleasure. You'll also appreciate the standard RIT feature.

Wide Frequency Coverage. On 80, 40 and 20 meters you get complete band coverage. Plus MARS frequencies without modification to the transceiver.

The Alda 105 covers all the 15 meter band, and from 28.5 to 29.0 MHz on 10 meters. Optional crystals are available for additional coverage on 10 meters, including the novice band.



The PS-130 delivers 30 amps regulated and requires 117v or 220v, 50/60 Hz input.



The PS-115 delivers 18 amps unregulated and requires 117v or 220v, 50/60 Hz input.

Mobile Power. The transceiver requires a nominal 13.8 volts dc input at 20 amps. When you oper-

ate mobile, just connect the transceiver directly to the battery.

Base-Station Power. For base-station operation, you'll need an ac power supply. The Alda PS-130 will give you full rated power on SSB and CW. The PS-115 will give you full power on SSB and 75% of full power on CW.

Summary Specifications.

Frequency Coverage... 3.50 to 4.05, 6.95 to 7.50, 13.95 to 14.50, 20.95 to 21.50, 28.45 to 29.00 MHz

Input Power
With power from car or Alda PS-130...

250 watts PEP or dc on 80, 40 and 20 meters, 200 watts PEP or dc on 15 and 10 meters

With power from Alda PS-115...

250 watts PEP/200 watts dc on 80, 40 and 20 meters, 200 watts

PEP/175 watts dc on 15 and 10 meters

Dimensions... 3 3/4 inches (82 mm) high, 9 inches (228 mm) wide, 12 1/2 inches (317 mm) deep

Weight... 8 1/2 lbs. (3.77 kg)

\$595 Introductory Price. See your dealer or write to us directly for ordering information. Our address is Alda Communications, Inc., 215 Via El Centro, Oceanside, CA 92054. Phone (714) 433-6123.

Here are the prices of optional accessories which you can buy now or later.

Model HM-1 Microphone...	\$ 14.95
Model MM-1 Mobile mount...	3.95
Model PC-701 Noise Blanker.....	39.95
Model PC-801 Dual xtal calibrator, 100 kHz and 25 kHz.....	19.95
Model PS-115 Power supply	84.95
Model PS-130 Power supply	149.95

alDa 105

We're proud it's built in the U.S.A.

SST T-4

ULTRA TUNER DELUXE



ULTRA TUNER DELUXE Matches any antenna—coax fed or random wire on all bands (160-10 meters). Tune out the SWR on your antenna for more efficient operation of any rig. Home, mobile, portable—only 9" x 2½" x 5" • 300 watt RF output capability • SWR meter with 2-color scale • Antenna Switch selects between two coax fed antennas, random wire, or tuner bypass • Efficient Airwound inductor • 208 pf. 1000V. Capacitors • Attractive bronze finished enclosure.

only \$64.95

SST T-2 ULTRA TUNER

Tunes out SWR on any antenna—coax fed or random wire (160-10 meters). Any rig—up to 200 watts RF output. Rugged, yet compact: 5¼" x 2¼" x 2¼".



only \$37.95

SST T-3 MOBILE IMPEDANCE TRANSFORMER

Matches 52 ohm coax to the lower impedance of a mobile whip. Taps between 3 and 50 ohms. 3-30 MHz. 300 watts output. 2¼" x 2" x 2¼".



only \$19.95

SST T-1 RANDOM WIRE ANTENNA TUNER

All bands (160-10 m.) with any wire • 200W output • Any transceiver • Home or portable • Neon tune-up indicator.



only \$29.95

SST DL-1 K&RLJ DUMMY LOAD. 1000W PEP. 1.5:1 1-225 MHz. Sealed. 3-1/8" x 4-3/8".

only \$17.95

SST CL-1 24 HR. CLOCK. Giant red LED numerals. Month and day also at push of button. Beautiful for your desk. 110VAC.

only \$22.95

SST B-1 BALUN for balanced lines. 300W.

only \$5.00

Call (213) 376-5887 to order C.O.D., VISA, or Master Charge.

To Order:

Send a check or money order—or use your M.C. or VISA. Add 8% shipping and handling. Calif. residents, add sales tax.

Guarantee: All SST products are unconditionally guaranteed for 1 year. In addition, they may be returned within 10 days for a full refund (less shipping) if you are not satisfied for any reason.

SSS

ELECTRONICS

P.O. BOX 1 LAWNSDALE, CALIF.
90260 • (213) 376-5887

... at last ...

your shack organized!

A beautiful piece of furniture — your XYL will love it!

\$149⁹⁵ S-F RADIO DESK

Deluxe - Ready to Assemble

Designed with angled rear shelf for your viewing comfort and ease of operation.

FINISHES: Walnut or Teak Stain.

Also available in Unfinished Birch, \$134.95.

Additional Information on Request.

Checks, Money Orders, BankAmericard and Master Charge Accepted.

F.O.B. Culver City. (In Calif. Add 6% Sales Tax.)

S-F AMATEUR RADIO SERVICES

DEPT. HZ-12 • 4384 KEYSTONE AVENUE • CULVER CITY, CALIF. 90230 — PHONE (213) 837-4870



Radio equipment not included

Floor Space: 39" Wide 30" Deep

KLAUS QUALITY AMATEUR RADIO EQUIPMENT & ACCESSORIES

KENWOOD

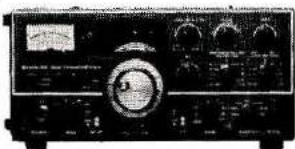

TS 520 S
HF TRANSCEIVER

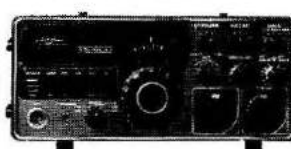

TS 600
MULTIMODE 6-M
TRANSCEIVER

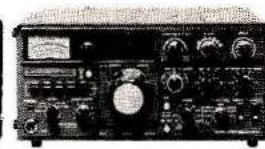

TS 820 S
HF TRANSCEIVER

... call or write for the KLAUS price ...

YAESU



FT-901 D
HF TRANSCEIVER



FT-227 R
2-METER FM TRANSCEIVER

... call or write for the KLAUS price ...

CUSHCRAFT

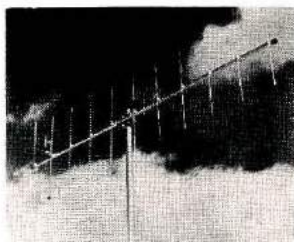

We have a complete stock of Cushcraft antennas — too many to mention in detail, so ask about our 2-meter line of verticals and beams for special low, low prices.

KLAUS RADIO Inc.

8400 N. Pioneer Parkway, Peoria, IL 61614

Phone 309-691-4840

Tim Daily, Amateur Equipment Sales Manager

ALL BAND TRAP ANTENNAS!

PRE-TUNED - COMPLETELY ASSEMBLED - ONLY ONE NEAT SMALL ANTENNA FOR UP TO 6 BANDS! EXCELLENT FOR CONGESTED HOUSING AREAS - APARTMENTS! LIGHT - STRONG - ALMOST INVISIBLE!

FOR ALL MAKES & MODELS OF AMATEUR TRANSCEIVERS - TRANSMITTERS - GUARANTEED FOR 2000 WATTS 5SB 1000 WATTS CW. FOR NOVICE AND ALL CLASS AMATEURS!

COMPLETE AS SHOWN with 90 ft. RG58U-52 ohm feedline, and PL259 connector, insulators, 30 ft. 300 lb. test dacron end supports, center connector with built in lightning arrester and static discharge - molded, sealed, weatherproof, resonant traps 1"X6"-you just switch to band desired for excellent worldwide operation - transmitting and receiving! WT. LESS THAN 5 LBS.

160-80-40-20-15-10 bands 2 trap---149 ft. with 90 ft. RG58U - connector - Model 777BU ... \$59.95
80-40-20-15-10 bands 2 trap --- 102 ft. with 90 ft. RG58U - connector - Model 998BU ... \$54.95
40-20-15-10 bands 2 trap --- 54ft. with 90 ft. RG58U coax - connector - Model 1001BU ... \$53.95
20-15-10 bands 2 trap --- 26 ft. with 90 ft. RG58U coax - connector - Model 1007BU ... \$52.95

SEND FULL PRICE FOR POST PAID INSURED DEL. IN USA. (Canada is \$5.00 extra for postage - clerical - customs - etc.) or order using VISA Bank Americard - MASTER CHARGE - AMER. EXPRESS. Give number and ex. date. Ph 1-308-236-5333 9AM - 6PM week days. We ship in 2-3 days. ALL PRICES WILL INCREASE \$5.00 SEPT. 1 - SAVE - ORDER NOW! All antennas guaranteed for 1 year. Money back trial! Made in USA. FREE INFO. AVAILABLE ONLY FROM.

WESTERN ELECTRONICS

Dept. AH-6

Kearney, Nebraska, 68847

Attention HAMS LOOKING for a great tower?

Do not attempt to raise antenna or antenna support near power lines - YOU CAN BE KILLED!

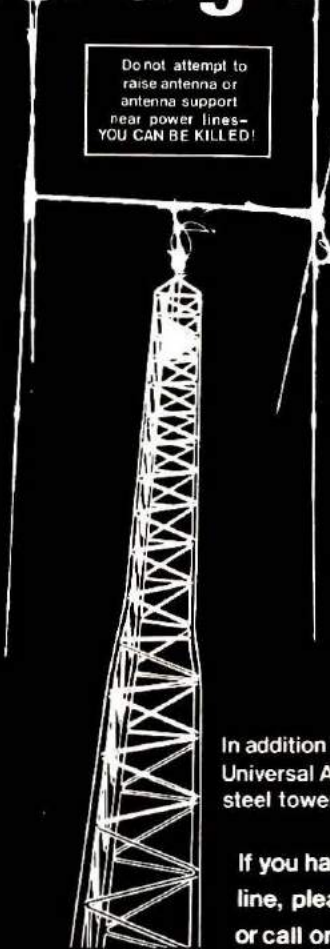

Three good reasons to use Universal Towers

- 1. LIGHT WEIGHT** - In addition to its weight advantages, aluminum offers maintenance-free lifetime beauty. Eliminates painting and ugly rust inherent in steel towers.
- 2. EASY ASSEMBLY** - Child's play to assemble. You can easily put together a tower on the ground and walk it up, or assemble it erect section by section.
- 3. STRENGTH** - Important to your choice of a tower. Universal Towers are tested to withstand the force of 80 m.p.h. winds and are designed to resist winds exceeding that velocity.

In addition to all of these advantages, the total cost of a Universal Aluminum Tower is less than that of similar steel towers extended over the life of the tower.

If you have any questions regarding our product line, please contact your local distributor or call or write for information.

UNIVERSAL TOWERS

Universal Manufacturing Co. 12357 E. 8 Mile Rd. Warren, Mich. 48089 [313] 774-4140
FREE STANDING ALUMINUM TOWER

Reliability Service Experience



WANTED: Any working ham radio transceiver, with manual! REWARD: \$250 to be credited toward the purchase of a new KENWOOD TS-600. (Example: TS-600 \$759, less trade in of Drake TR-22 @ \$250. Your balance \$509.)



KENWOOD TR-7600 plus STACO RPS-8 six amp power supply (\$59.95 retail) all for **\$375**

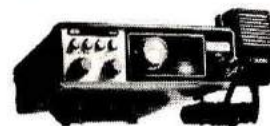

YAESU FT-227RA plus STACO RPS-8 six amp power supply all for **\$399**



KENWOOD TS-820S, list \$1299
RSE price **\$1049**

KENWOOD R-820, list \$1099
RSE price **\$929**

KENWOOD TL-922A, list \$1199
RSE price **\$1024**



Quantities limited. Michigan residents add 4% sales tax. Please include your area code and telephone number with any correspondence.



RSE HAM SHACK

NOW AT TWO LOCATIONS
1207 W. 14 MILE, CLAWSON, MI 48017
(313) 435-5660
31155 PLYMOUTH, LIVONIA, MI 48150
(313) 522-4232

**Paper costs up,
Printing costs up,
Postage costs up,
Up, Up, Up . . .**

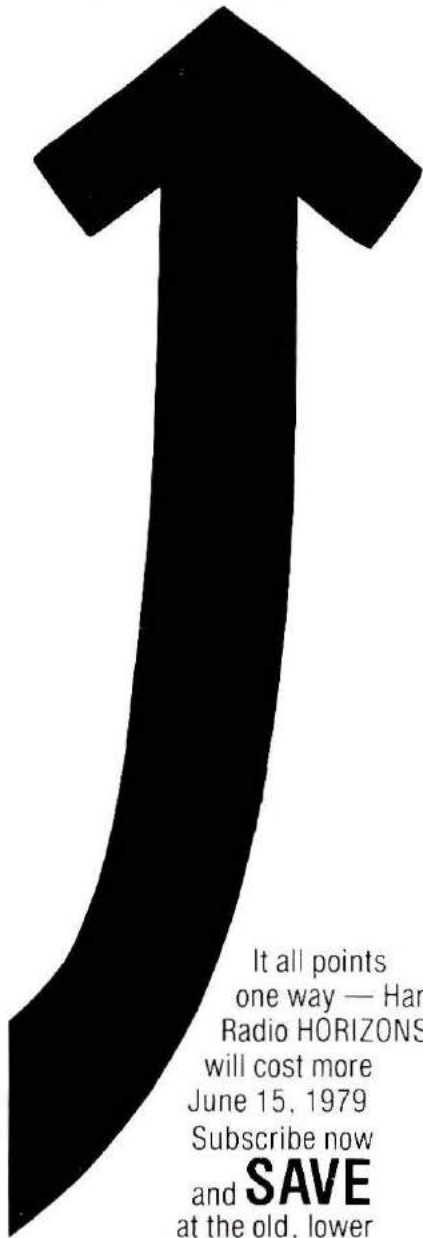

It all points
one way — Ham
Radio HORIZONS
will cost more
June 15, 1979
Subscribe now
and **SAVE**
at the old, lower
rates

- 1 year **Just \$10.00**
(\$12 after June 15)
- 2 years **Just \$18.00**
(\$20 after June 15)
- 3 years **Just \$24.00**
(\$27 after June 15)

(use the handycard included in this issue or complete below)

New Extension Renewal

For payment enclose check, money order or charge
card information (acct. #, expire date, bank # for
Master Charge)

Name _____ Call _____

Address _____

City _____ State _____ Zip _____



model sw-5 heavy duty —
REMOTE CONTROLLED ANTENNA SWITCH — \$135.00 plus \$3 shipping
• order direct or write for brochure •

ANTENNA MART

515-292-7114

box 1010, i.s.u. station, ames, iowa 50010

*our little boxes
replace a lot of cable!*

- select any of five antennas at the turn of a knob, with just one feedline and a control cable to the remote switching unit •
- saves coax, simplifies station layout •
- handles 4 kw p.e.p. •
- other models to nine positions •
- full one-year warranty •

THE BIG SIGNAL
UNADILLA
"W2AU" Baluns

DEMANDED BY
PROFESSIONALS
WORLD-WIDE
OVER 12 YEARS

- The Original Lightning Arrest
- 650^W Strength
- Stainless Hardware
- Sealed
- GUARANTEED

ASSISTANCE?
Call: HUGH GUNNISON, WA2ZOT
Toll-Free 800-448-1666
[NYS Collect 315-437-3953]

Still
Only
\$14.95



FOR HIGHEST ANTENNA
EFFICIENCY
1:1 OR 4:1
2,000W
PEP

**FULL-POWER, QUALITY
HAM ANTENNA PARTS
AT YOUR DEALER**

- BALUNS - TRAPS - INSULATORS
- QUAD PARTS - ANTENNA KITS
- BOOM/MAST MOUNTS - WIRE
- CABLE - CONNECTORS

WRITE FOR FULL CATALOG
[Enclose 30¢ Stamps]

MICROWAVE
FILTER
JFC COMPANY, INC.
6743 KINNE STREET, EAST SYRACUSE, NEW YORK 13207

UNADILLA/REYCO DIVISION [Dept. HRH]

DEALERS WANTED - OVER 300 WORLD-WIDE

**THIS IS IT
Bird**



MODEL 4431 THRULINE®

RF DIRECTIONAL WATTMETER
with VARIABLE RF
SIGNAL SAMPLER - BUILT IN
IN STOCK FOR PROMPT DELIVERY
AUTHORIZED DISTRIBUTOR

Webster
associates

115 BELLARMINE
ROCHESTER, MI 48063

CALL TOLL FREE
800 - 521-2333

IN MICHIGAN 313 - 375-0420

Hobbyists

Here is an interesting general electronics hobby magazine. It's loaded with lots of interesting simple circuits and ideas, not only about radio, but in all phases of electronics including test gear, audio, remote control and security systems. We are sure that you will find a number of worthwhile projects in this British magazine.

1 Year (12 issues) \$15.00
Radio & Electronics Constructor
Greenville, NH
03048



100 watts speaks for itself!

**NOW
\$699**

The NEW Swan 100 MX Mobile Transceiver

Just imagine... over 100 watts of mobile power on 10 thru 80 meters, at your fingertips! The Swan MX-100 is compact in size, but not in performance. Noise blanker circuitry, RIT control ± 15 KHz and a host of other features are built in. Swan's reputation for value engineering backed by their 90 day warranty policy make this 100 watt solid state mobile the right rig for you. Call and order yours today and be "rag-chewing" tomorrow! Suggested Manufacturer's List, ~~\$849.95~~

Technical Specifications: Semi-CW break-in, built-in VOX, operates from 11 to 15 VDC, current drain 130ma receive and 20 amps maximum in transmit at 13.0 VDC. Internal speaker, mobile mount bracket, retractable tilt stand, PSU-5 power supply with speaker for ham shack operation. ST-3 Matching Antenna Tuner available as matching accessory.

Call Jim for your
AR Net Price Quote **(716) 235-7540**

**PRICES
SLASHED FOR YOUR
SUMMER MOBILING
PLEASURE. CALL RIGHT
AWAY WHILE THEY LAST.**

JR Amateur Radio

1185 SCOTTSVILLE RD., ROCHESTER, NEW YORK
14624

MADISON DOUBLE YOUR WARRANTY POLICY

Any large piece of gear we sell you (average \$300 or up) we will **double** your warranty period!

FOR EXAMPLE: A 3 month warranty = 6 months from date of purchase. 1 year = 2 years from date of purchase.

*(OUR RELIABLE SERVICE DEPARTMENT REPAIRS
NON-WARRANTY GEAR, TOO!)*

Simply send your rig in a good shipping carton, postage prepaid, with a copy of your receipt showing date of purchase. We will repair promptly and return by best way.

NOTE: Manufacturers do not cover final in most cases, but we will try!

Try Our Competitive Prices, Too!

You, the customer, can only benefit from the Madison **Double Your Warranty Policy**.

Call **Don - K5AAD** or **Mike - W5VVM** for specific warranty claim questions.

POLICY SUBJECT TO CHANGE WITHOUT NOTICE



MADISON

Electronics Supply, Inc.

1508 McKinney, Houston, TX 77002, 713/658-0268

SINCE 1932

Portland Radio Supply Co.

DAH-DIT-DAH-DIT DAH-DAH-DIT-DAH

OREGON RESIDENTS — CALL TOLL FREE
800-452-0908
TO ORDER DESK — PORTLAND STORE



EQUIPMENT — PARTS

Sales & Service

- AMIDON • AMP • ASTATIC
- AMPHENOL • BUD • BOMAR
- CRYSTALS • BOOKS & CODE
- TAPES • CONTINENTAL SPECIAL-
- TIES • COVERCRAFT • CHICAGO MINIATURE
- CINCH • DATAK • GC • GE • IDJ • ICO/RALLY • JIM-PAK
- LMB • LPS • LUXO • LITTLEFUZE • MOTOROLA HEP • NYE
- OK MACHINE & TOOLS • PANAVISE • SIMPSON • SUPEREX
- SWITCHCRAFT • SPRAGUE • SHURE • TURNER • UNGAR
- VECTOR • WAHL • WELLER/XCELITE • WIRE: ALPHA-CON-
- SOLIDATED, JSC. SAXTON • PLUS FULL LINE OF AMATEUR
- EQUIPMENT.

**SALES & SERVICE AT
TWO LOCATIONS IN OREGON**

1133 SOUTH RIVERSIDE AVE.
MEDFORD, ORE. 97501
503-773-5815

1234 S.W. STARK ST.
PORTLAND, ORE. 97205
503-228-8647

YOU ASKED FOR IT YOU GOT IT

DSI

QUIK-KIT®

50 HZ TO 550 MHZ COUNTER KIT

95% ASSEMBLED 100% TESTED
Performance You Can Count On

FREQUENCY COUNTER APPLICATION:

- Ham Radio — Two Way Radio — CB
- Audio Amplifier & Receiver Repair
- Computer Maintenance & Construction
- A Must for TV & PLL Repair

\$99.95
MODEL 3550K

includes built-in
Pre-Amp & Prescaler



DSI OFFERS THE BEST OF TWO WORLDS . . .

An unprecedented DSI VALUE . . . in a high quality, LSI Design, 50 HZ to 550 MHZ frequency counter kit. And, because it's a DSI innovation, you know it obsoletes all competitive makes, both in price & performance.

With 95% of the assembly completed by DSI, you are only one hour away from solving all of those difficult bench problems, from adjusting 60 HZ clock-time bases to setting the frequency of a 468 MHZ Mobile Radio.

FACT: Every 3550 QUIK-KIT® PC board is factory assembled and tested before shipment. **FACT:** The problems of bad LED's, IC's, and Capacitors are a thing of the past. **FACT:** No manufacturer except DSI offers a 550MHZ frequency counter with . . . 8 digits, .5 in. LED's, TCXO, 1HZ resolution and a one year warranty on parts for under \$100.00. **FACT:** We do not know how long we can hold this low, low price. **GO WITH THE LEADER . . . BUY A DSI FREQUENCY COUNTER KIT TODAY. SAVE TIME & MONEY AND BE ASSURED IT WILL WORK THE FIRST TIME.**

DSI — GUARANTEED SPECIFICATIONS

Time Base TCXO 1PPM 65° to 85°F
Freq. Range 50HZ to 550MHZ incl. two SO239 inputs
Resolution 1HZ to 65MHZ, 10HZ to 550MHZ
Gate Time 1 sec & 1/10 sec with Auto Decimal Point
Display 8 digits, ½ inch LED with Leading Zero Blanking
Sensitivity 25MV @ 25MHZ, 150MHZ, 250MHZ;
75MV @ 450MHZ
Power Batt., 12VDC @ 300Ma, 110VAC (with AC-9)

3550K Kit	\$99.95
T-101 Ant.	3.95
AC-9 AC Adp.	7.95
Shipping, Handling, Ins.	10.00

3550W Wired	149.95
T-101 (incl.)	NC
AC-9 (incl.)	NC
Shipping (incl.)	NC

CALL TODAY TOLL FREE: (800-854-2049) Cal. Res. CALL (800-542-6253) TO ORDER OR RECEIVE MORE INFORMATION ON DSI'S FULL PRODUCT LINE OF FREQUENCY COUNTERS RANGING FROM 10HZ TO 1.3GHZ

TERMS: MC - VISA - AE - Check - M.O. - COD in U.S. Funds. Orders outside of USA & Canada, please add \$20.00 additional to cover air shipment. California residents add 6% Sales Tax.

DSI INSTRUMENTS, INC.

7924 Ronson Road, Dept. G, San Diego, CA 92111

AMERICAN EXPRESS



VISA

DSI Super Meter

Transistor Tester — VOM

Diode Protected • Fused • Gold Plated Selector Switch



- DC VOLTAGE
- DC CURRENT
- AC VOLTAGE
- Ω RESISTANCE
- AF OUTPUT — DB
- 20k Ω PER VOLT
- HFE DC AMP FACTOR
- ICEO LEAKAGE

\$ 29⁹⁵
 MODEL YF-370
 COMPARATIVE VALUE 49⁹⁵

YF-370 \$29.95
 Shipping, Handling and Ins. . . \$3.00

Every YF-370 is factory assembled, tested, and includes diode protected meter movement with a fused input and an extra fuse. The switch assembly has double wiping gold plated contacts to assure years of trouble-free service. At this low price buy two...one for the car and one for the shop.



(800—542-6253)

(800—854-2049)

TERMS: MC — VISA — AE — Check — M.O. — COD in U.S. Funds.
 Orders outside of USA & Canada, please add \$5.00 additional to cover air shipment. California residents add 6% Sales Tax.

DSI INSTRUMENTS, INC.

7924 Ronson Road, Dept. G, San Diego, CA 92111

SPECIFICATIONS

Measurement	Measurement Ranges	Accuracy
DCV	0 - .1V - 5V - 2.5V - 10V - 50V - 250V - 1000V	$\pm 3\%$ fs
ACV	0 - 10V - 50V - 250V - 1000V 30Hz to 30kHz	$\pm 4\%$ fs
DCA	0 - 50 μ A - 2.5ma - 25ma -.25A	$\pm 3\%$ fs
Ω	.2 to 20m Ω Range x 1 x 10 x 1k x 10k	$\pm 3\%$ arc
dB	+10db~+22db for 10VAC	$\pm 4\%$ fs
ICEO	0 - 150 μ A x 1k 0 - 15ma x10 0 - 150m x 1	$\pm 3\%$ arc
HFE	0 - 1000 @ x 10 $\frac{I_c}{I_n}$	$\pm 3\%$ arc

OUR PERFORMANCE SPEAKS FOR ITSELF!

pace COMMUNICATOR

PATHCOM INC. AMATEUR PRODUCTS GROUP
24105 SOUTH FRAMPTON • HARBOR CITY, CA 90710

CALL TOLL FREE 800-421-1196



NEW FOR TWO!

Butternut introduces two new verticals for the two meter band.

← MODEL 2MCV COLLINEAR BASE STATION VERTICAL

This high performance antenna provides gain and a very low angle of radiation similar to that expected from a three half wave collinear array. Quarter wavelength resonant radials prevent feedline radiation, pattern distortion, and undesirable cancellation of low angle radiation.

MODEL 2MJV J-POLE BASE STATION VERTICAL →

This simple, rugged vertical antenna provides a low angle of radiation and gain similar to that of a one full wave radiator. The easy assembly and low price are hard to beat.

QSL for info!



BUTTERNUT ELECTRONICS COMPANY

Route 1 Lake Crystal, Mn. 56055

ROSS DISTRIBUTING COMPANY



Ross J. Hansen, WB7BYZ
78 South State, Preston, Idaho 83263
(208) 852-0830

Ross Specials: Looking for a good buy in Ham Gear? Call all the Watts lines first, then call me. I will be \$1.50 to \$40.00 less depending on the amount of your purchase. Plus I want to be sure that you are happy with your selection. We have Kenwood, Yaesu, Icom, Ten-Tec, Drake, Dentron, Hygain, ETO, Mosley, Cush-Craft, Hustler, Larsen, Taylor, MFJ, etc. We have the largest stock and best selection of amateur equipment in the Intermountain West. Call (208) 852-0830. Close Mondays at 2 p.m.



Please send all reader inquiries directly

The Personal Antenna

...Custom created with Hustler components.

Make your choice of Hustler components. Aluminum and chrome plated brass mast with bumper mounting or stainless steel 180° adjustable ball fender/deck mount. Standard 500 watt PEP resonators or Super 2 KW PEP resonators with large "Hi-Q" computer designed inductor and stainless steel tip rod. Optional quick disconnect stainless steel resonator spring. Quality manufactured 50 ohm coax. You want top performance. That's why you should customize with the MO/RM series antennas and components from Hustler, the name recognized for personal quality in antennas!



3275 North B. Ave. • Kissimmee, Florida 32741

Clearly the choice of those who know quality.



DEALERS

Amateur Electronic Supply
 4828 West Fond du Lac Ave.
 Milwaukee, WI 53216
 414-442-4200

Amateur Radio Supply
 6213 - 13th Ave., S.
 Seattle, WA 98108
 206-767-3222

Appliance & Equipment Co.
 2317 Vance Jackson
 San Antonio, TX 78213
 512-734-7793

Electronic Center, Inc.
 127 Third Ave., N.
 Minneapolis, MN 55401
 612-371-5200

Quement Electronics, Inc.
 P.O. Box 6000
 San Jose, CA 95150
 408-998-5900

Route Electronics 46, Inc.
 225 Route 46
 Totowa, NJ 07512
 201-256-8555

MAXI TUNER

SOLVES ANTENNA PROBLEMS

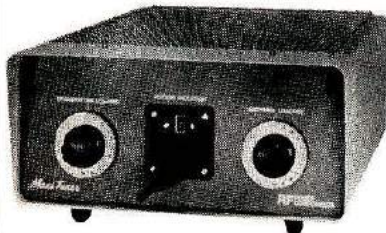

THE FINEST

ANTENNA TUNER AVAILABLE

- Presents 50-75 Ohm Resistive Load to Your Transmitter Using Virtually Any Antenna System
- Improved Ultimate Transmatch Circuit Matches Coax, Random Wire and Balanced Antennas
- Continuous 1.7-30 MHz Coverage
- 229-203 Rotary Inductor (28 μH)
- Rugged Cast Aluminum Turns Counter
- Handles 3 KW PEP
- Heavy Duty Balun
- Velvet-Smooth 6 to 1 Vernier Tuning
- 0-100 Logging Scale on Capacitors
- Available in Kit Form or Assembled
- One Year Factory Warranty
- Use with your present SWR meter or wattmeter.
- Custom Vacuum Capacitor Designs and Individual Components Available

Call or Write for Pricing, Spec Sheet, and FREE Amateur Market Antenna Tuner Comparison Chart That Tells It Like It Is!

RF POWER COMPONENTS
 P. O. Box 11
 Ladysmith, WI 54848
 (715) 532-3971

LUNAR Preamplifiers

Tired of talking farther than you hear?

The LUNAR preamp series is the most complete on the market.

- Both receiving and inline models available
- Special application preamps at your request

MODEL	DESCRIPTION	LIST
PA 28	28 MHz preamp, BNC or RCA	\$35.95
PA 50	50 MHz preamp, BNC or RCA	35.95
PA 144	144 MHz preamp, BNC or RCA	35.95
PA 220	220 MHz preamp, BNC or RCA	35.95
PA 144K-T	144 MHz preamp, RCA w/TS-700A kit	5.00
PA 144K-F	144 MHz preamp, RCA w/FT-221 kit	5.00
PAI 28	28 MHz inline preamp, BNC or SO-239	49.95
PAI 50	50 MHz inline preamp, BNC or SO-239	49.95
PAI 144	144 MHz inline preamp, BNC or SO-239	49.95
PAI 20	220 MHz inline preamp, BNC or SO-239	49.95
PAD-144	144 MHz dual preamp, 22 dB gain	45.95
PAD-220	220 MHz dual preamp, 20 dB gain	45.95
PAI-50D-s	50 MHz inline mini-preamp	51.95
PAI-144D-s	144 MHz inline mini-preamp	51.95
PAI-220D-s	220 MHz inline mii-preamp	51.95
PA 432-2	420-450 MHz preamp	41.95
PAF 432-2	420-450 MHz preamp, w/input filter	51.95
PAE 432-5	420-450 MHz preamp, ultra-low NF	64.95



MADISON ELECTRONICS

1508 McKinney • Houston, TX 77002
 (713) 658-0268

The 1979 Atlanta HamFestival and Georgia State ARRL Convention June 16-17, 1979

Downtown Atlanta Marriott Hotel

- GIANT covered Fleamarket/Swapshop!
- More than 25 Forums/Meetings!
- FCC Exams!
- Parking for thousands of cars!
- 140 Major Exhibits!
- Special MICROPROCESSOR Section!
- Programs for Ladies & Children!
- Activities Galore!

Registration: \$3 per person IN ADVANCE, \$4 at the door
Children FREE!

If you do not receive a Preregistration Packet by May 1st, write:

Atlanta HamFestival 1979
100 Woodlawn Drive
Marietta, Georgia 30067

Hotel Rates: \$32 per day single OR double!

Write for Hotel Reservations to:

Marriott Hotel • Courtland at International Blvd. • Atlanta, GA 30303
or phone: Area 404/659-6500 and hurry, hurry, hurry!

THE BEST HAMFEST IN THE WORLD!

Introducing Microcraft's New Morse-A-Word

- * Eight character moving display
- * All solid state reliability
- * Compact size - fits almost anywhere
- * Complete - no CRT or expensive extras needed
- * Built-in code practice oscillator
- * Ideal for beginners, SWL's and seasoned amateurs
- * 5 to 35 WPM speed range
- * Connects to your receiver speaker



The MORSE-A-WORD decodes audio signals from your receiver's loudspeaker and displays letters, numbers, punctuation and special morse characters visually as the code is received. Excellent for learning the code and great for general short wave listeners. Write for special information on building the MORSE-A-WORD units as a club project.

MORSE-A-WORD Kit with 4 character readout MAWK-4 \$149.95
MORSE-A-WORD Kit with 8 character readout MAWK-8 \$169.95
Morse-A-Word wired & tested with 8 character readout MAWF \$249.95

Send check or money order. Use your VISA or Master Charge. Add \$3.50 shipping and handling. Wisconsin residents add 4% State Sales Tax.

Microcraft Corporation
P. O. Box 513, Thiensville, Wisconsin 53092

New!



Twice as much for less.

HR-LB Here's the log book everyone is talking about. This new offering from HRB is far superior to any other log available today! With over 2,000 entries, you have twice as much space for less cost in comparison to its nearest competitor. There are 80 big (8½ x 11) pages, 30 entries per page for an "easy-count" during contests, a frequency spectrum chart, call sign prefixes and much more. This is unquestionably the best log book value anywhere. 80 pages. ©1978. Spiralbound.

\$1.75

Send check, money order or credit
card information plus \$1.00 shipping to:

Ham Radio's Bookstore
Greenville, NH 03048

LUNAR'S **NEW** Portable Erectable Antenna Towers

- Ideal for ground or roof mounts
- One man can assemble and erect
- Lightweight
- High quality aluminum alloy
- High stability
- Modular and portable
- Extremely rugged

These unique antenna towers can be installed on the ground or roof. Since they're easily transported and site erected, they're a natural for field and portable operations.

Constructed of sturdy aluminum alloy, they're sturdy enough to handle large size HF beams and EME arrays as well. Also available with optional stainless steel hardware for harsh environments.

Base is approximately 60" high and weighs 28 pounds. Tower sections are 72" high and weigh 21 pounds.

Base plus
1 tower section
with cad hardware.
Suggested
List Price . . .

\$179⁹⁵

CALL M & M FOR PACKAGE DEAL DISCOUNT! (714) 299-9741

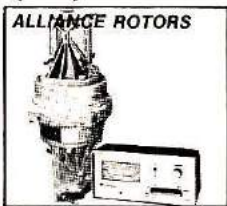
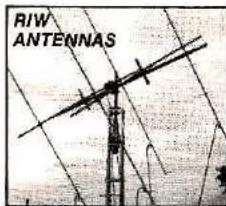

M&M RF DISTRIBUTORS
P.O. BOX 82183, SAN DIEGO, CA 92138

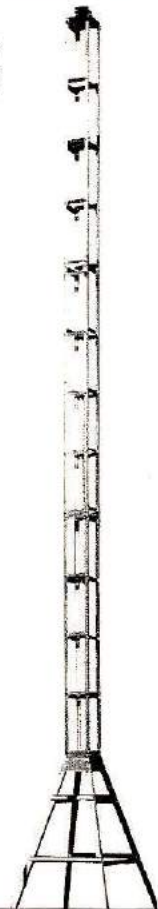

RAVE REVIEWS

"I want to express my thanks for a beautiful job. They fit just fine and I am very well pleased."
Norm Howard, W1JBV

"The workmanship and quality are excellent. Well worth the money."
Gene Amaral

"Thanks for the 'expedite' on the covers! As usual, they fit fine!"
Keith Baker, WD8CMU

"Again, thank you for the covers. They fit perfectly as have the other covers I've ordered from your company in the past."
Phil Wilson, WA4MCP



And "Thank you, Folks," for your kind words. Cover Craft Dust Covers are available at more than 90 Amateur retailers.
Why wait any longer?

COVER CRAFT
P.O. Box 555, Amherst, NH 03034
Telephone (603) 673-8592

Call or Write for Delivery or Quote

KENWOOD TS-120S

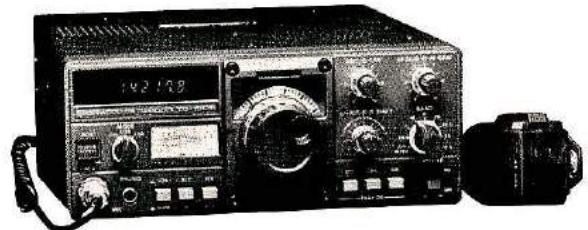

MADISON ELECTRONICS SUPPLY, INC.

1508 MCKINNEY • HOUSTON, TEXAS 77002
713/658-0268

LEAVE A MESSAGE & WE'LL CALL YOU BACK!

HRH LOCATOR

TO HELP YOU FIND YOUR LOCAL AMATEUR RADIO DEALER

Arizona

POWER COMMUNICATIONS

6012 N. 27 AVENUE
PHOENIX, AZ 85017
602-242-6030
Arizona's #1 "Ham" Store,
Kenwood, Yaesu, Drake, ICOM,
& more.

California

C & A ELECTRONIC ENTERPRISES

22010 S. WILMINGTON AVE.
SUITE 105
P. O. BOX 5232
CARSON, CA 90745
800-421-2258
213-834-5868 - Calif. Res.
Not the biggest, but the best —
since 1962.

JUN'S ELECTRONICS

11656 W. PICO BLVD.
LOS ANGELES, CA 90064
213-477-1824 Trades
714-282-8682 San Diego
The Home of the One Year
Warranty — Full Service.

SANT ELECTRONICS CO.

8106 S. SORENSEN
SANTA FE SPRINGS, CA 90670
213-698-1388
Amateur Sales and Service.
See Rick WB6EWE or Gary WD6FWQ.

SHAVER RADIO

3550 LOCHINVAR AVE.
SANTA CLARA, CA 95051
408-247-4220
Atlas, Kenwood, Yaesu, KDK,
Icom, Tempo, Wilson, Ten-Tec.

Connecticut

THOMAS COMMUNICATIONS

95 KITTS LANE
NEWINGTON, CT 06111
800-243-7765
203-667-0811 - Conn. Res.
Call Us Toll Free —
See Our Full Page Ad in this Issue.

Delaware

DELAWARE AMATEUR SUPPLY

71 MEADOW ROAD
NEW CASTLE, DE 19720
302-328-7728
Delaware's Largest Stock of
Amateur Radio Equipment
& Accessories.

Florida

AGL ELECTRONICS, INC.

1800-B DREW STREET
CLEARWATER, FL 33515
813-461-HAMS
West Coast's Only Full Service
Amateur Radio Store

AMATEUR RADIO CENTER, INC.

2805 N.E. 2ND AVENUE
MIAMI, FL 33137
305-573-8383
The Place For Great Dependable
Names in Ham Radio

RAY'S AMATEUR RADIO

1590 US HWY. 19 SOUTH
CLEARWATER, FL 33516
813-535-1416
Atlas, B&W, Bird, Cushcraft,
DenTron, Drake, Hustler, Hy-Gain,
Icom, K.D.K., Kenwood, MFJ,
Rohn, Swan, Ten-Tec, Wilson.

Illinois

AUREUS ELECTRONICS INC.

1415 N. EAGLE STREET
NAPERVILLE, IL 60540
312-420-8629
"Amateur Excellence"

ERICKSON COMMUNICATIONS, INC.

5456 NORTH MILWAUKEE AVE.
CHICAGO, IL 60630
312-631-5181
Illinois (Outside 312)
800-972-5841
Outside Illinois 800-621-5802
Hours 9:30-5:30 Mon., Tues., Wed.,
Fri.; 9:30-9:00 Thurs.; 9:00-3:00 Sat.

KLAUS RADIO, INC.

8400 NO. PIONEER PARKWAY
PEORIA, IL 61614
309-691-4840
Let Us Quote Your Amateur Needs.

SPECTRONICS, INC.

1009 GARFIELD STREET
OAK PARK, IL 60304
312-848-6777
One of America's Largest
Amateur and SWL Stores

Iowa

BOB SMITH ELECTRONICS

RFD #3, HIGHWAY 169 & 7
FORT DODGE, IA 50501
515-576-3886
For an EZ Deal on New
or Used Equipment.

Kansas

ASSOCIATED RADIO COMM

8012 CONSER
OVERLAND PARK, KS 66204
913-381-5900
America's No. 1 Real Amateur Radio
Store. Trade - Sell - Buy.

Maryland

THE COMM CENTER INC.

9624 FT. MEADE ROAD
LAUREL PLAZA RT. 198
LAUREL, MD 20810
800-638-4486
R. L. Drake, Ten-Tec, ICOM, Swan,
Tempo, Wilson, DenTron, Mosley.

Massachusetts

TEL.COM, INC.

675 GREAT RD., RT. 119
LITTLETON, MA 01460
617-486-3040
The Ham Store of New England
You Can Rely On.

TUFTS ELECTRONICS

209 MYSTIC AVENUE
MEDFORD, MA 02155
617-395-8280
New England's Friendliest
Ham Store.

Minnesota

PAL ELECTRONICS INC.
3452 FREMONT AVE. NO.
MINNEAPOLIS, MN 55412
612-521-4662
Midwest's Fastest Growing Ham
Store. Where Service Counts.

Nebraska

COMMUNICATIONS CENTER, INC.
443 N. 48 STREET
LINCOLN, NE 68504
800-228-4097
Kenwood, Yaesu, Drake and More
at Discount Prices.

Nevada

COMMUNICATIONS CENTER WEST
1072 RANCHO DRIVE
LAS VEGAS, NV 89106
800-634-6227
Kenwood, Yaesu, Drake and More
at Discount Prices.

New Hampshire

EVANS RADIO, INC.
BOX 893, RT. 3A BOW JUNCTION
CONCORD, NH 03301
603-224-9961
Icom, DenTron, Yaesu, Drake.
We service what we sell.

New Jersey

ATKINSON & SMITH, INC.
17 LEWIS STREET
EATONTOWN, NJ 07724
201-542-2447
Ham supplies since '55'.

**BARGAIN BROTHERS
ELECTRONICS**
216 SCOTCH ROAD
GLEN ROC SHOPPING CTR.
WEST TRENTON, NJ 06828
609-883-2050
A million parts — Lowest prices
anywhere. Call us!

METUCHEN RADIO
216 MAIN STREET
METUCHEN, NJ 08840
201-494-8350
New and Used Ham Equipment.
WA2AET "T" Bruno

RADIOS UNLIMITED
P. O. BOX 347
1760 EASTON AVENUE
SOMERSET, NJ 08873
201-469-4599
New Jersey's Fastest
Growing Ham Store.

New York

AM-COM ELECTRONICS INC.
RT. 5
NORTH UTICA SHOPPING CTR.
UTICA, NY 13502
315-732-3656
The Mohawk Valley's Newest and
Largest Electronics Supermarket.

HAM-BONE RADIO
(Div. Stereo Repair Shop)
3206 ERIE BOULEVARD EAST,
SYRACUSE, NY 13214
315-446-2266
We Deal, We Trade,
We Discount, We Please!

HARRISON RADIO CORP.
20 SMITH STREET
FARMINGDALE, NY 11735
516-293-7990
"Ham Headquarters USA®"
since 1925.
Call toll free 800-645-9187.

RADIO WORLD
ONEIDA COUNTY AIRPORT
TERMINAL BLDG.
ORISKANY, NY 13424
800-448-7914
315-337-2622 } NY
315-337-0203 } Res.
New & Used Ham Equipment. See
Warren K2IXN or Bob WA2MSH

Ohio

**AMATEUR RADIO
SALES & SERVICE INC.**
2187 E. LIVINGSTON AVE.
COLUMBUS, OH 43209
614-236-1625
Antennas and Towers
for all services.

COMMUNICATIONS WORLD, INC.
4788 STATE ROAD
CLEVELAND, OH 44109
216-398-6363
Repairs on all HF Gear
regardless of age.

Pennsylvania

ELECTRONIC EXCHANGE
136 N. MAIN STREET
SOUDERTON, PA 18964
215-723-1200
Demonstrations, Sales, Service.
New/Used Amateur Radio Equip.

**HAMTRONICS, DIV. OF
TREVOSE ELECT.**
4033 BROWNSVILLE RD.
TREVOSE, PA 19047
215-357-1400
Same Location for
More Than 30 Years.

LaRUE ELECTRONICS
1112 GRANDVIEW STREET
SCRANTON, PENNSYLVANIA 18509
717-343-2124
ICOM, Bird, Cushcraft, CDE,
Ham-Keys, VHF Engineering,
Antenna Specialists.

South Dakota

**BURGHARDT
AMATEUR CENTER, INC.**
P. O. BOX 73
WATERTOWN, SD 57201
605-886-7314
"America's Most Reliable
Amateur Radio Dealer".

Texas

HARDIN ELECTRONICS
5635 EAST ROSEDALE
FORT WORTH, TX 76112
817-461-9761
You Bet Fort Worth
Has A Ham Store!

Dealers:

You should be
here too! Contact
HORIZONS today
for complete details.

TOLL
FREE **800-258-5353**

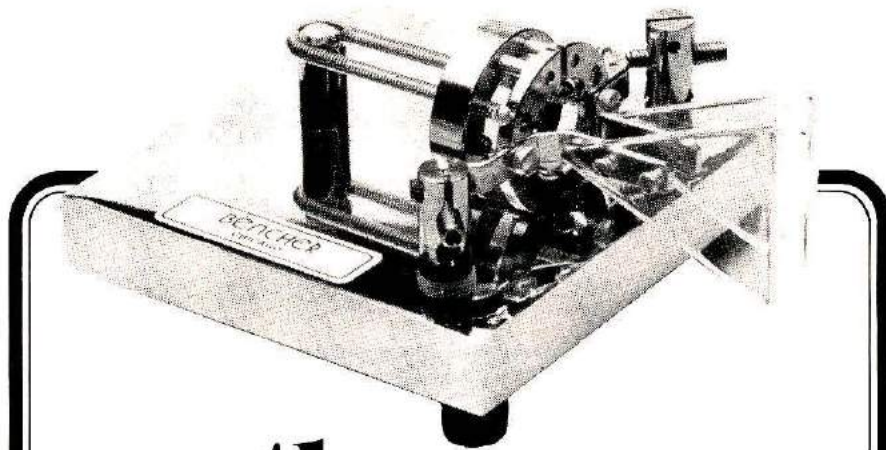

the Ultimate IAMBIC PADDLE

WRITE FOR LITERATURE

BENCHER, INC.

333 W. Lake Street, Dept. A
Chicago, Illinois 60606 • (312) 263-1808

- Full range of adjustment in tension and contact spacing.
- Self-adjusting nylon and steel needle bearings.
- Solid silver contact points.
- Polished lucite paddles.
- Precision-machined, chrome plated brass frames.
- Standard model has black, textured finish base; deluxe model is chrome plated.
- Heavy steel base; non-skid feet.

Available at selected dealers or send \$39.95 (\$49.95 for chrome model) plus \$2.00 shipping and handling. Overseas amateurs invited to request quotation for air parcel post shipment.

NEWCOMER OR OLD PRO . . . ALPHA POWER IS YOUR KEY TO A BIG SIGNAL



ALPHA/VOMAX can boost the "talk power" of any rig up to ten times or more. The new SBP-4 split band speech processor uses the only system more effective than rf clipping — AND distortion is extremely low so your voice sounds natural. Under tough conditions VOMAX can help as much as most linears. Combine VOMAX with a good linear and WOW! It's simple to install and operate with any rig.



ALPHA 76A is a heavy-duty "rock crusher" . . . a full kilowatt (2 + KW PEP), No Time Limit, all-band desk top linear amplifier . . . a no-compromise ALPHA with a TWO YEAR FACTORY WARRANTY.

Other superb ALPHA's include the "ULTIMATE LINEAR" ALPHA 77Dx and two new models that require NO TUNE UP at all to delivery maximum legal power, with No Time Limit, on all bands. Call or write your dealer or ETO direct for detailed literature on all ALPHA products.



EHRHORN TECHNOLOGICAL
OPERATIONS, INC.
P.O. BOX 708, CANON CITY, CO 81212
(303) 275-1613

GEM-QUAD FIBRE-GLASS ANTENNA FOR 10, 15, and 20 METERS

Two Elements \$159.00
Extra Elements \$113.00
Price is F.O.B. Transcona
INCLUDES U.S. Customs
Duty

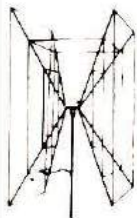

KIT COMPLETE WITH
*SPIDER
*ARMS
*WIRE
*BALUN KIT
*BOOM WHERE
NEEDED

WINNER OF MANITOBA
DESIGN INSTITUTE
AWARD OF EXCELLENCE

Buy two elements now — a third and fourth may be added later with little effort.

Enjoy up to 8 db forward gain on DX, with a 25 db back to front ratio and excellent side discrimination.

Get maximum structural strength with low weight, using our "Tridetic" arms. Please inquire directly to:

GEM QUAD PRODUCTS LTD.

Box 53
Transcona Manitoba
Canada R2C 2Z5
Tel. (204) 866-3338

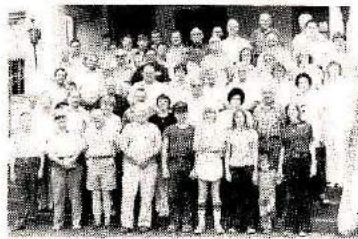

July 28 thru August 10, 1979

Our 20th year of successful teaching

**Boost your Ham Skills
on the Blue Ridge**

"A Vacation with a Purpose"

Two weeks saturation learning program in Amateur Radio:

- Novice to General
- General or Technician to Advanced
- Advanced to Amateur Extra

Expert Instruction starting at your level. Code and Theory in depth along with Friendly Amateurs, Who Care About You.

C. L. PETERS, K4DNJ, Director
Oak Hill Academy Amateur Radio Session
Mouth of Wilson, Virginia 24363

Name _____ Call _____
Address _____
City/State/Zip _____

HELP!

Anytime you have a question about your Ham Radio HORIZONS subscription, please include a mailing label to insure prompt service on your inquiry.

**CHANGE
OF ADDRESS**

Moving? Please let us know 4-6 weeks beforehand. Or, if anything is wrong with your current mailing label, please carefully print the updated information below and affix your present label above.

PLEASE HELP US TO SERVE YOU BETTER

**HAM RADIO
HORIZONS** Greenville, NH 03048

Call _____
Name _____
Address _____
City _____
State _____ Zip _____

AFFIX
LABEL
HERE



CODE got you stumped?

RELAX and worry not! Learn international Morse Code the EASY, Rus Farnsworth way. No books, no gimmicks, just listen & learn. Using the word method, based on modern psychological techniques, you can zoom past 13 w.p.m. in **less than half the time!** Available in cassettes @ \$10.95 and LP records at \$9.95 — you get over **two hours** of instruction!

EPSILON RECORDS

P.O. Box 626, San Jacinto, CA 92383

NEW CONCEPT — Novice instructional package, theory tape & study material. Complete license study package, \$17.95. General study package, \$19.95. MARI, 1320 Canary Drive, West Columbia, SC 29169.

VIRGINIA: "Ole Virginia Hams" A.R.C. Hamfest, June 3, 1979, Prince William County Fairgrounds, Route 234, 1/2 mile south of Manassas. Gates open 7 A.M. for tailgaters, 8 A.M. to public. Admission \$3 — children under 12 free. Tailgating \$2 per vehicle — over 300 spaces available. Fantastic prizes, food and beverages until 2:30 P.M., FM clinic, YL program, childrens' program, CW proficiency, QSL bureau program. Indoor exhibit space for dealers and manufacturers. Requests for information: Sam Lebowich, WB4HAV, OVHARC, P.O. Box 1255, Manassas, Virginia 22110.

ANTENNA HOMEBREWERS: Complete line of aluminum, fiberglass, and stainless-steel antenna hardware. We will custom-design for you or supply to your design at prices you can't beat! GL Enterprises, Route 1, Box 10G, Brownsville, Wisconsin 53006. (414) 583-4001.

STOP LOOKING for a good deal on amateur radio equipment — you've found it here — at your amateur radio headquarters in the heart of the Midwest. Now more than ever where you buy is as important as what you buy! We are factory-authorized dealers for Kenwood, Drake, Yaesu, Collins, Wilson, Ten-Tec, Atlas, ICOM, DenTron, MFJ, Tempo, Regency, Hy-Gain, Mosley, Alpha, Cushcraft, Swan and many more. Write or call us today for our low quote and try our personal and friendly Hoosier service. HOOSIER ELECTRONICS, P.O. Box 2001, Terre Haute, Indiana 47802. (812) 238-1456.

WANT QSLs FAST? Send \$9.95 for 100 multi-colored sent return mail! (\$4.00 each additional hundred!) Satisfaction guaranteed! ARC; Box #1171; Garland, Texas 75040.

QSLs with class! Unbeatable quality, reasonable price. Samples: 50¢ refundable. QSLs Unlimited, 1472 SW 13th Street, Boca Raton, FL 33432.

CUSTOM Printed and photo QSL's, very economical; free samples, stamp appreciated. Stu, K2RPZ, Box 412, Rocky Point, N. Y. 11778. (516) 744-6260.

RADIO EXPO '79 September 15 and 16, 1979, Lake County Fairgrounds, Routes 120 and 45, Grays Lake, Illinois. Manufacturer's displays, flea market, seminars, ladies' programs. Advance tickets \$2.00. Write EXPO, P.O. Box 305, Maywood, IL 60153. Exhibitors inquiries: EXPO Hotline (312) 345-2525.

FREQUENCY ALLOCATION CHART. See how the entire radio spectrum is used. 2 kHz to 200 GHz. Send \$3.00. Collins Chart Co., Box 935, Coronado, CA 92118.

CUSTOM EMBROIDERED EMBLEMS — Your design, low minimum. Informational booklet. Emblems, Dept 65, Littleton, New Hampshire 03561.

CLUB CALL PINS — 3 lines 1 1/4" x 3/4" \$1.55 each. Call, first name and club. Colors blue black or red with white letters. (Catalog) Arnold Linzner, 2041 Linden Street, Ridgewood, N. Y. 11227.

NAMETAGS — 1 1/2" x 2 1/2" — One line \$2.50. Each additional line \$0.50. 12 colors. Tag-it Co., Box 2062, Indianapolis, IN 46206.

CODE PRACTICE OSCILLATORS, hand keys, electronics keyers, other products. Free catalog. Globaiman (W6PHA) Products, Box 388-HO, El Toro, CA 92630. 714-533-4400.

RATES Regular classified is available at 50¢ per word. Display classified (1 inch deep x 2 1/4 inches wide) is \$65, or at the 12x rate is \$50. All Ad Scan payable in advance. No cash discounts or agency commissions allowed.

HAMFESTS Sponsored by non-profit organizations receive one free regular classified ad (subject to our editing). Repeat insertions of hamfest ads pay the standard rate.

COPY No special layout or arrangements available. Material should be typewritten or clearly printed (not all capitals) and must include full name and address. We reserve the right to reject unsuitable copy. HORIZONS cannot check each advertiser and thus cannot be held responsible for claims made. Liability for correctness of material limited to corrected ad in next available issue.

DEADLINE 15th of third preceding month.

SEND MATERIAL TO: Ad Scan, Ham Radio Horizons, Greenville, N. H. 03048.

SCANNER OWNERS! "Top Secret Registry of U.S. Government Radio Frequencies (25 to 470 MHz)" by K2AES! Only book of its kind ever published! 2,250+ listings of: FCC, FBI, Secret Service, CIA, Customs, Border Patrol, Immigration, NASA, Treasury, FAA, military, and more! Only \$4.95, ppd. CRB Research, Box 56-HR, Commack, NY 11725.

MASSACHUSETTS: NoBARC Hamfest July 21, 22 at Cummington Fairgrounds. Tech talks, demonstrations and dealers. Flea market, \$1.00; advance registration \$3.00 single, with spouse \$5.00 to Tom Hamilton, WA1VPX, 206 California Avenue, Pittsfield, Massachusetts 01201 or \$4.00/\$6.00 at gate. Mobile talk-in on 146.31/91. Gates open at 5:00 P.M. on Friday for free camping.

QSL's — samples 25¢ — K3QK, 226 Waldorf St., Pittsburgh, PA 15214.

NOVICES: Relax and improve skills with eight important operating aids on heavy 11 x 17" card. CW abbreviations, ending and Q signals, punctuation, R-S-T, U.T.C. conversion & more. \$2. Postpaid WD5KFN, Albany, TX 76430.

QSLs & RUBBER STAMPS — Top Quality! QSLs: Glossy Inks and Cardstock. Rubber Stamps: Report forms, Call Letter, Address, State outlines — More! Stamp Catalog and Card Samples 50¢. Ebbert Graphics 5H, Box 70, Westerville, Ohio 43081.

QSL CARDS 500/\$10. 400 illustrations, sample. Bowman Printing, 743 Harvard, St. Louis, MO 63130.

EZ DEALS are hard to beat. Try me and see for new or used ICOM, Cushcraft, KLM, Yaesu, Drake, Wilson, VHF Eng., Ten-Tec, Swan, DenTron, CDE, Hustler, Larsen, and more. W0EZ, Bob Smith Electronics, RFD 3, Fort Dodge, Iowa 50501. (515) 576-3886.

WISCONSIN: CWRA Swapfest Picnic, June 3, 1979, Stevens Point. For info write W9BCC, Frank Guth, 1632 Ellis Street, Stevens Point, WI 54481.

PRINT YOUR OWN QSL Cards with a custom made 3" x 5" Rubber Stamp. Guaranteed to please. Send your copy with a check or money order for \$12.50 to: Market, 305 So. Hudson St., Westmont, Ill. 60559.

PENNSYLVANIA: Milton A.R.C. Hamfest, June 3, 1979 at the Allenwood Firemen's Fairgrounds, U.S. Route 15, four miles north of Interstate 80. Doors open 8 A.M. \$2.50 advanced, \$3 gate; children and spouses FREE. Flea market, auction, contests, portable/mobile FM clinic, prizes, food & beverages. Talk-in on 146.37/97; 146.34/94 repeaters and 146.52 simplex. Details from Kenneth Hering, WA3JUU, R.D.#1, Box 381, Allenwood, Pennsylvania 17810; Telephone (717) 538-9168.

MOBILE IGNITION SHIELDING provides more range with no noise. Bonding strap sale less than 50¢ each. Literature. Estes Engineering, 930 Marine Drive, Port Angeles, Wash. 98362.

ILLINOIS: Six Meter Club of Chicago presents the 22nd Annual ABC Hamfest, Sunday, June 10, 1979 at Santa Fe Park, 91st & Wolf Road, Willow Springs, Illinois. Registration \$1.50 advance, \$2 at gate. Features large swappers row, picnic grounds, plenty of parking, refreshments, pavillion displays, AFMARS meeting, color TV, etc. Advance tickets from Val Hellwig, K9ZWW, 3420 South 80th Court, Cicero, Illinois 60650. Talk-in on 146.94 or WR9ABC on 146.37/97 (PL2A).

WANT UP-TO-DATE INFORMATION? "Radio-Hobbyist Newsletter" issued every two weeks. Only \$5.00 per year! Guaranteed! ARC; Box 1171-G; Garland, Texas 75040.

QSLs SECOND TO NONE. Same day service. Samples 50 cents. Include your call for free decal. Ray, K7HLR, Box 331, Clearfield, UT 84015.

ELECTRONIC BARGAINS, CLOSEOUTS, SURPLUS! Parts, equipment, stereo, industrial, educational. Amazing values! Fascinating items unavailable in stores or catalogs anywhere. Unusual FREE catalog. ETCO-059, Box 762, Plattsburgh, N.Y. 12901.

HAMFEST — Official ARRL 5th Annual Hall of Fame Hamfest, Stark County Fairgrounds, Canton, Ohio, Sunday, July 15. Mobile check in on 19-79 or 52-52. \$2.50 advanced; \$3.00 at gate. Contact WA8SHP, 10877 Hazelview Ave., Alliance, Ohio 44601.

QSL CARDS — Eyeball Cards — Rubber Stamps — Name Tags — Emblems — Gift Items — Free Catalog — Rusprint, Box 7575, Kansas City, MO 64116.

CALL TOLL FREE

For the best deal on

- AEA • Ameco • ASP • Atlas
- Belden • Bencher • Bird
- CDE • CIR • CES • Cushcraft
- DenTron • Drake • Hy-Gain
- Icom • KLM • Kenwood
- Larsen • MFJ • Midland
- Mosley • NPC • Newtronics
- Nye • Palomar • Regency
- Shure • Swan • Standard
- Tempo • Ten-Tec • Tonna
- Transcom • Wilson • Yaesu

NEAR CHICAGO?

COME IN AND SEE US!



Tim KA9DGO and Mike WN9ANF
serving you!



CALL TOLL FREE
FOR THE ERICKSON PRICE!

OUTSIDE ILLINOIS: (800) 621-5802



Hours:

9:30-5:30 Mon., Tues., Wed. & Fri.

9:30-9:00 Thursday

9:00-3:00 Saturday



ERICKSON

COMMUNICATIONS, INC.

5456 N. MILWAUKEE AVE.

CHICAGO, IL 60630 (312) 631-5181

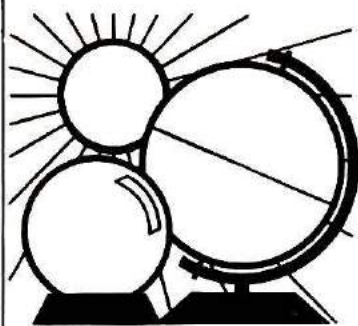

DX FORECASTER

The DX word this month is GOOD, with a mixed bag of opportunities in which DX activity is likely to be as prevalent on vhf as it is on hf!

The seven-day period between June 6th and 13th is likely to be disturbed, with maximum effects most likely to be felt on the 7th or 8th. Such disturbances could produce aurora in the ionosphere, and atmospheric storms, giving rise to auroral as well as tropospheric propagation. Sporadic E activity is likely on many days of the month, making *ten*, *six* and even *two* meters likely candidates for skip contacts.

For the best current information about changing conditions as they affect DX, tune in WWV at eighteen minutes after each hour for up-to-date reports of ionospheric and geomagnetic-field conditions.

Band-by-band predictions

Twenty meters will be open to one part of the world or another during each day, except for occasional disturbed days, with an early morning spate of activity followed by late afternoon and evening DXing. Short skip to about 1600 kilometers (1000 miles) will occur during midday on most days.

Fifteen meters should be the best overall DX band in June, with openings occurring during early morning and late afternoon hours. Hours surrounding midday will be best for short skip out to about 1900 kilometers (1200 miles) while extended north-south path DX is expected during the afternoon and evening.

Ten meters will be excellent on many days of the month, offering an incredible variety of

propagation conditions from which to choose. Expect long and short skip, long and short path DX, and an occasional disturbance to keep your days full of interesting happenings. Considering the low power required for good signal strengths, you can have as much or more fun on *ten* than on any other band. Midday is short-skip time with regular openings out to about 2000 kilometers (1200 miles).

Six meters is likely to open more frequently than in any previous year of the past decade. Not only short skip of 2000 to 2500 kilometers (1200 to 1500 miles) on many days, but the added bonus of long-haul DX between the USA and South and Central America — possibly even to Hawaii and Africa on a super day — will cheer the hearts of the avid DX-chasers.

Eighty, forty, and one-sixty meters are not considered to be summertime DX bands. Occasional openings on *forty* in the late evenings will bring happiness, particularly on north-south paths. High static levels, plus high signal absorption levels, render *eighty* and *one-sixty* practically useless, but — if you're willing to try — check them out on that rare cold and clear evening when QRN slacks off to bearable levels. Early morning or late, late evening attempts on these bands are best for DXers. Short skip of 500 to 1200 kilometers (300 to 800 miles) on 80, and 1100 to 1600 kilometers (700 to 1000 miles) on 40 can be expected up to mid-morning, and following mid-afternoon hours.

HRH





WESTERN USA

MID USA

EASTERN USA

GMT	PDT	WESTERN USA								MID USA								EASTERN USA								
		ASIA	EUROPE	S. AFRICA	S. AMERICA	ANTARCTICA	NEW ZEALAND	OCEANIA	JAPAN	ASIA	EUROPE	S. AFRICA	S. AMERICA	ANTARCTICA	NEW ZEALAND	OCEANIA	JAPAN	ASIA	EUROPE	S. AFRICA	S. AMERICA	ANTARCTICA	NEW ZEALAND	OCEANIA	JAPAN	
		N ↑	NE ↗	E →	SE ↘	S ↓	SW ↙	W ←	NW ↖	N ↑	NE ↗	E →	SE ↘	S ↓	SW ↙	W ←	NW ↖	N ↑	NE ↗	E →	SE ↘	S ↓	SW ↙	W ←	NW ↖	
0000	5:00	15	15	20	10	—	10	10	10	15	15	20	15	—	10	15*	15	15	15	20	20	20	—	10	15	15
0100	6:00	15	15	20	10	—	10	10	10	15	15	20	15	—	10	15*	15	15	15	20	20	20	—	10	15	15
0200	7:00	15	10	—	10	—	10	10	10	10	15	20	15	—	10	15	15	15	20*	20	20	20	—	10	15	20*
0300	8:00	15	10	—	10	—	10	10	10	10	—	—	15	—	15*	15	15	15	20	20	20	20	—	15	15	20
0400	9:00	15	10	20	15	—	10	10	10	10	—	—	15	—	15	15	20	20	20	20	20	20	—	15	20	20
0500	10:00	20	10	15	15	—	10	10	10	10	—	—	15	—	15	15	20	20	20	20	20	20	—	15	20	20
0600	11:00	20	10	10	15	—	15*	15	10	10	15	20	15	—	15	15	20	20	20	20*	15	—	15	20	20	20
0700	12:00	20	10	10	15	—	15	15	10	—	10	—	—	—	15	15	20	20	20	20	20	20	—	20	20	—
0800	1:00	20	—	10	20	—	15	15	10	—	15*	—	—	—	15	15	20	—	—	15	—	—	20	20	—	
0900	2:00	20	—	10	—	—	20	15	10	—	—	—	—	—	20	15	—	—	—	20*	—	—	20	—	—	
1000	3:00	20	—	10	—	—	20	15	10	—	—	—	—	—	20	15	—	—	—	20	—	—	20	—	—	
1100	4:00	—	—	10	—	—	20	15	—	—	—	—	—	—	20	15	—	—	—	20	—	—	20	—	—	
1200	5:00	—	—	15	20	—	20	15	—	20	15	20	15	—	20	20	—	—	—	20	—	—	20	—	—	
1300	6:00	20	10	20	20*	20	20	15	—	20	10	15	10	15	20	15	20	20	20	15	15*	20	20	—	—	
1400	7:00	20	10	20	15	20	20	15	15*	10	10	15	10	15	20	15	20	20	20	15	10	20	20	20	—	
1500	8:00	20	10	20*	15	20	20	15	10	10	10	15	10	20	20	15	20	20	20	10	10	20	20	20*	20	
1600	9:00	15	10	15	15	20	—	15	15*	10	10	15	10	20	—	20	20*	15	10	10	10	20	—	15	20	
1700	10:00	15	10	15	15	20	—	15	15	10	10	15	10	20	—	20	20	15	10	10	10	20	—	15	20	
1800	11:00	15	10	15	10	20	—	15	15*	10	10	15	10	20	—	20	20	15	10	10	10	20	—	15	20	
1900	12:00	15	10	15	10	20	—	15	15*	10	10	15	10	20	—	20	20	15	10	10	10	20	—	15	20	
2000	1:00	15	10	15	10	20	—	10	10	15	10	15	10	20	—	20	20	15	10	10	10	20	—	15	15	
2100	2:00	15	10	15	10	20	10	10	10	15	10	15	10	20	—	15	15*	15	10	10	10	20	—	15	15	
2200	3:00	15	10	15	10	20	10	10	10	20*	15	10	15	—	10	15*	15	15	15	15	15	—	10	15	15	
2300	4:00	15	10	15	10	—	10	10	10	20	15	15*	15	—	10	15*	15	15	15	20	15	—	10	15	15	

JUNE

SUNDAY	MONDAY	TUESDAY	WEDNESDAY	THURSDAY	FRIDAY	SATURDAY
<p>*All international events such as contests are shown on the GMT days on which they take place even though they may actually begin on the evening of the preceding day in North America.</p> <p>Central Wisconsin SWAPfest Picnic — Stevens Point, WI WAZOQ Hamfest '79 — 1510 Speedway, NY — WB2ALW 1240 Midwest ARC Hamfest — info: Kenneth Hering, W4JUU, RD #1, Box 381, Woodford, VA Ohio Valley Hamfest — info: Kenneth Hering, W4JUU, RD #1, Box 381, Woodford, VA One Virginia Hamfest — info: Kenneth Hering, W4JUU, RD #1, Box 381, Woodford, VA On the Shore ARC Hamfest — Prince William County Fairgrounds, 10000 Old Dominion Rd., Fairfax, VA On the Shore ARC Hamfest — Prince William County Fairgrounds, 10000 Old Dominion Rd., Fairfax, VA South Shore ARC Hamfest — Auction — Irving Club — 410 Quincy Avenue — Braintree, MA Slated Rock RC Hamfest — Bureau County Fairgrounds — Princeton, IL Tri-State Area Hamfest — Camden Park — Huntington, WV</p>	<p>FLORIDA HAM NEWS — SWAP NET By the Broward ARC 146.31-91 at 7:30PM GLENHURST RADIO SOCIETY Transmits Amateur Radio News WR2APB and 21.400 MHz USB WEST COAST BULLETIN Edited & Transmitted by W6CZ 9PM PST 3500 KHZ, A-1, 22 WPM</p>	<p>AMSAT Eastcoast Net 3850 kHz 9PM EDT (0100Z Wednesday Morning) AMSAT Mid-Continent Net 3850 kHz 9PM CDT (0200Z Wednesday Morning) AMSAT Westcoast Net 3850 kHz 8PM PST (0300Z Wednesday Morning)</p>	<p>Club members operate with include G3, G5N, YB, GB, G4, AMX, CVZ, EST, FR, GB, SHS, GHT, GAF, HGT, HSF, G6, G4V, CFM, FHD, WXX, NRD. Participation in the RCGA VHF national field day is intended. Disting will be 100% ether via the bureau to G3AMD or direct (including the appropriate ICS) to G. H. Cohen G4CHS, 41 South Station Road, Gateacre, LIVERPOOL, Merseyside L25 3DE, England</p>	<p>AMATEUR FAIR '79 Swapfest/Exposition — Minnesota State Fairgrounds — St. Paul, MN Bridge City ARC Convention — Red Carpet Inn — Beaumont, TX — 8-3 Minnesota OSC Party — 18002, 6/2 — 28552 6/3 Nebraska OSC Party — 2-3</p>	<p>ARRL, VNE OSC Party — 9-10 ARRL Georgia State Convention — Atlanta, GA — 16-17 ARRL Michigan Repeater Association Hamfest — Ridgeland County Fairgrounds — Ridgeland, MI ARRL New York State Convention — Columbia Park — Dunellen, NJ ARRL Oklahoma State Convention — Oklahoma City — 10002, 6-15, 10002, 6-17 ARRL Texas OSC Party — 23002, 6-18 — 33002, 6-17</p>	<p>ARRL Field Day — 23-24 CO FIELD DAY CO FIELD DAY CO FIELD DAY </p>
<p>ISLE OF MAN MILLENIUM EXPLORATION — The Liverpool and District Amateur Radio Society are mounting a 4 Day expedition to the Isle of Man during the period of the special, GT prefix to celebrate one thousand years of the Island's Parliament, Tyrnwald. The club's call sign, G13AHQ/Parable, will be used during this period (2000-6:29 to 2300Z 7/8) and operation will be on an HF band. Suggested frequencies plus or minus 500K are as follows: CW — 1.820-835, 3.505, 7.005, 14.080, 21.080, 28.080 589 — 1.820-835, 3.695/780, 7.092, 14.195/275, 21.244/275, 28.495/550 144 290, 432 290</p>	<p>FLORIDA HAM NEWS — SWAP NET By the Broward ARC 146.31-91 at 7:30PM GLENHURST RADIO SOCIETY Transmits Amateur Radio News WR2APB and 21.400 MHz USB WEST COAST BULLETIN Edited & Transmitted by W6CZ 9PM PST 3500 KHZ, A-1, 22 WPM</p>	<p>AMSAT Eastcoast Net 3850 kHz 9PM EDT (0100Z Wednesday Morning) AMSAT Mid-Continent Net 3850 kHz 9PM CDT (0200Z Wednesday Morning) AMSAT Westcoast Net 3850 kHz 8PM PST (0300Z Wednesday Morning)</p>	<p>AMSAT Eastcoast Net 3850 kHz 9PM EDT (0100Z Wednesday Morning) AMSAT Mid-Continent Net 3850 kHz 9PM CDT (0200Z Wednesday Morning) AMSAT Westcoast Net 3850 kHz 8PM PST (0300Z Wednesday Morning)</p>	<p>Louisville Area Computer Club Computerfest — Bluegrass Convention Center, Louisville, KY — 6/29 — 7/1 Young Ladies' Radio League, Inc. International Convention — Holiday Inn 4th and Arch — Philadelphia, PA — WB2UCJ 6/29 — 7/1</p>	<p>ARRL West Virginia State Convention — Jackson's Mill, WV — 6-30-7/1 Seven-Land OSC Party — 6-30 — 7/1</p>	<p>ARRL Field Day — 23-24 CO FIELD DAY CO FIELD DAY CO FIELD DAY </p>
<p>Monroe County Radio Communications Association Hamfest/Swap V, Shop off Route 4 at West Road between Torrington and Goshen, CT — info: Fred Lux, W0BZ2, P.O. Box 982, Monroe, MI 48151 Shore Point ARC Hamfest — Stockton State College Campus — Pomona, CA South Shore ARC Hamfest — 14000 S. Santa Fe Pkwy., 91st Street and West Road — W. New Springs, IL</p>	<p>FLORIDA HAM NEWS — SWAP NET By the Broward ARC 146.31-91 at 7:30PM GLENHURST RADIO SOCIETY Transmits Amateur Radio News WR2APB and 21.400 MHz USB WEST COAST BULLETIN Edited & Transmitted by W6CZ 9PM PST 3500 KHZ, A-1, 22 WPM</p>	<p>AMSAT Eastcoast Net 3850 kHz 9PM EDT (0100Z Wednesday Morning) AMSAT Mid-Continent Net 3850 kHz 9PM CDT (0200Z Wednesday Morning) AMSAT Westcoast Net 3850 kHz 8PM PST (0300Z Wednesday Morning)</p>	<p>AMSAT Eastcoast Net 3850 kHz 9PM EDT (0100Z Wednesday Morning) AMSAT Mid-Continent Net 3850 kHz 9PM CDT (0200Z Wednesday Morning) AMSAT Westcoast Net 3850 kHz 8PM PST (0300Z Wednesday Morning)</p>	<p>See June 2, 5, 6, 16, 19, 23, 30</p> 	<p>ARRL Field Day — 23-24 CO FIELD DAY CO FIELD DAY CO FIELD DAY </p>	

Novice, QRP, 200 w, deluxe — good, better, best — \$299, \$369, \$399, \$699, \$869, \$899, \$1069. TEN-TEC has them all. A choice of seven HF transceiver models — a choice of power levels — a choice of operating features (and accessories) for beginner or old timer. Best of all, there's a wide choice of prices to fit every amateur budget.

TEN-TEC "OMNI" TRANSCEIVERS — REALLY CHOICE.

Top of the line. Deluxe in every respect. Deserving of a place in the finest of operating positions. All solid-state 100% duty cycle 200-watt final amp.; 8-bands (160-10 m plus convertible 10 MHz and "Aux" band positions); broadband design for no tune-up; built-in VOX and PTT; built-in Squelch; 4-position CW-SSB filter and 8-pole crystal filter with separate mode switch to permit using all filters in all modes; 2-speed break-in; 2-range offset tuning; optimized sensitivity from 2 μ V on 160 m to 0.3 μ V on 10 m; greater dynamic range (typically better than 90 dB) plus PIN diode switched 18 dB attenuator; WWV at 10 MHz; front panel control of linear/antenna bandswitching; phone patch jacks; "timed" crystal calibrator (on "A" model only); zero-beat switch; SWR bridge; adjustable ALC and sidetone; dual speakers; plug-in boards; "clamshell" aluminum case with black vinyl covering plus warm dark metal front panel; full shielding, optimum size for convenient operation: 5 $\frac{3}{4}$ "h x 14 $\frac{1}{4}$ "w x 14"d. Model 545 OMNI-A with analog dial, only \$899; Model 546 OMNI-D with six 0.43" LED digital readouts, \$1069. Model 645 keyer, \$85, Model 243 Remote VFO, \$139, Model 248 Noise Blanker, \$49, Model 252MO AC Power Supply, \$119.

TEN-TEC "ARGONAUT" TRANSCEIVER—QRP CHOICE.

The challenge and excitement of working the world on 5 watts. And every feature you need: all solid-state; 5 bands (80-10 m); full amateur band coverage SSB/CW; sensitivity less than 0.5 μ V; offset tuning; 4-pole IF crystal filter, 2.5 kHz bandwidth; analog dial; vernier tuning; automatic sideband selection; built-in speaker; 5-watt input to broadband push-pull final amplifier; PTT; full CW break-in; adjustable sidetone volume and pitch; built-in SWR bridge; TVI filter; plug-in boards; small and light weight enough to go anywhere (4 $\frac{1}{2}$ "h x 13"w x 7"d and 6 lbs.). World beating price, too: Model 509 only \$369; Model 210 AC Power Supply just \$34.

TEN-TEC 540/544 TRANSCEIVERS—POWER CHOICE.

200 watts from the bottom of 80 m to the top of 10 m — SSB or CW. No compromise from the leader in solid-state HF technology. Instant band change without tune-up; sensitivity 0.3 μ V; offset tuning; 8-pole crystal-lattice filter; WWV at 10 & 15 MHz; push-pull solid-state final amp.; 100% duty cycle; adjustable ALC with LED indicator; built-in SWR bridge; PTT; full CW break-in; adjustable sidetone pitch and vol.; zero-beat switch in Model 544. Choose the value leading Model 540 with analog dial and built-in 25 kHz pulsed calibrator for just \$699 or the Model 544 with six 0.43" LED digital readouts for \$869. Model 240 160M converter, \$110; Model 262M AC Power Supply with VOX, \$145; Model 252M AC supply only, \$119.

TEN-TEC CW TRANSCEIVERS—BUDGET CHOICE.

The "Century 21" series. Unique. Modern technology with old-fashioned value. Fine performance, reliability, and simplicity of operation, all at low cost. Win raves from novices and confirmed brass pounders alike. All solid-state; 5 bands (80-10 m) full amateur band coverage; receive CW and SSB, transmit CW; sensitivity 1 μ V or less; offset tuning; 3-position selectivity (2.5 kHz, 1 kHz, 500 Hz); 70 w input to push-pull Class C final amp.; broadbanded for no tune-up or resonating; full break-in; adjustable side-tone level; built-in AC power supply. Choose Model 570 with analog dial for only \$299; Model 574 has a 5 LED digital readouts for only \$399.

The choice is all yours when you choose TEN-TEC HF transceivers; see your nearest dealer or write for full details.



TEN-TEC, INC.
SEVIERVILLE, TENNESSEE 37862
EXPORT: 1715 LINCOLN AVE., CHICAGO, ILL. 60646

WIDEST CHOICE IN HF TRANSCEIVERS: TEN-TEC



AD CHECK

... for literature, in a hurry — we'll rush your name to the companies whose names you check.

Place your check mark in the space between name and number. Example: HRH 150.

ALDA ___ 625	MFJ ___ 082
ARRL * <input type="checkbox"/>	M&M RF Distr. ___ 577
Antenna Mart ___ 009	Madison * <input type="checkbox"/>
Atlanta Hamfest * <input type="checkbox"/>	Microcraft ___ 774
Atlas ___ 198	Microwave Filter ___ 637
Benchner ___ 629	Oak Hill Acad. A.R.S. * <input type="checkbox"/>
Butternut * <input type="checkbox"/>	Palomar Eng. * <input type="checkbox"/>
Commun. Center ___ 534	Pathcom ___ 705
Cornell-Dubilier ___ 241	Portland Radio ___ 719
Cover Craft ___ 685	RF Power Comp. ___ 542
Cushcraft * <input type="checkbox"/>	RSE Ham Shack ___ 607
DSI ___ 656	Callbook ___ 100
Drake * <input type="checkbox"/>	Constructor ___ 586
E.T.O. * <input type="checkbox"/>	Ross Distr. ___ 581
Erickson * <input type="checkbox"/>	S-F A. R. S. ___ 640
Gem Quad * <input type="checkbox"/>	SST ___ 375
Hal * <input type="checkbox"/>	Swan ___ 111
HRB ___ 150	Telrex ___ 377
Horizons ___ 150	Ten-Tec * <input type="checkbox"/>
Henry ___ 062	Thomas Comm. ___ 730
Hustler ___ 171	Tri-Ex ___ 116
Icom ___ 065	Universal Mfg. ___ 684
Int. Crystal ___ 066	Webster Assoc. ___ 423
JR ___ 752	Western * <input type="checkbox"/>
Kantronics * <input type="checkbox"/>	Wilson ___ 123
Kenwood * <input type="checkbox"/>	
Klaus ___ 430	
Larsen ___ 078	
Long's ___ 468	

*Please contact this advertiser directly.

Limit 15 inquiries per request.

JUNE 1979

Please use before July 31, 1979

Tear off and mail to
HAM RADIO HORIZONS — "Ad Check"
Greenville, N. H. 03048

NAME _____

CALL _____

STREET _____

CITY _____

STATE _____ ZIP _____

MADISON SUMMER CIRCUS

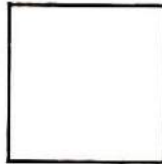

% WRITE IN
YOUR
BEST QUOTE
FROM THE
"800 GANG."

NOW, LIST THE EQUIPMENT YOU WANT IN THE SPACES PROVIDED BELOW, CUT OUT THIS AD, AND SEND IT TO US WITH YOUR NAME, ADDRESS AND TELEPHONE NUMBER. WE WILL WRITE OR CALL (CHECK ONE) YOU BACK AS SOON AS POSSIBLE WITH THE **MADISON** QUOTE.

(HINT: DON'T GO BELOW OUR COST).

WE HAVE AN IN-DEPTH STOCK AND LARGE INVENTORY OF MAJOR LINES AND ACCESSORIES.

PLEASE QUOTE ON:

1. _____	NAME _____
2. _____	ADDRESS _____
3. _____	TELEPHONE _____
4. _____	ZIP _____

TERMS: ALL PRICES FOB HOUSTON. PRICES SUBJECT TO CHANGE WITHOUT NOTICE. ALL ITEMS GUARANTEED. SOME ITEMS SUBJECT TO PRIOR SALE. SEND LETTERHEAD FOR AMATEUR DEALER'S PRICE LIST. TEXAS RESIDENTS ADD 6% TAX. PLEASE ADD POSTAGE ESTIMATE.

MADISON ELECTRONICS SUPPLY, INC.

1508-D McKINNEY HOUSTON, TEXAS 77002
713/658-0268 NITES 713/497-5683

AD INDEX

ALDA Communications	59
American Radio Relay League	47
Antenna Mart	62
Atlanta Hamfest	68
Atlas Radio Company	Cover IV
Benchner, Inc.	72
Butternut Electronics	66
Communications Center	80
Cornell-Dubilier Electric Co.	48
Cover Craft	69
Cushcraft	4
DSI Instruments	64, 65
Drake Co., R.L.	Cover II
Ehrhorn Technological Operations	72
Erickson Communications	74
Gem Quad Products	72
Hal Communications Corp.	1, 9
Ham Radio's Bookstore	48, 68
Ham Radio Horizons	62, 72
Henry Radio Stores	79
Hustler	67
Icom	7
International Crystal	35
JR Amateur Radio	63
Kantronics	48
Tri-Kenwood Communications, Inc.	Cover III
Klaus Radio Inc.	60
Larsen Antennas	47
Long's Electronics	40, 41
MFJ Enterprises	3
M&M RF Distributors	69
Madison Electronic Supply	63, 67, 69, 78
Microcraft Corporation	88
Microwave Filter, Inc.	62
Oak Hill Academy Amateur Radio Session	72
Palomar Engineers	46
Pathcom, Inc.	66
Portland Radio Supply Co.	63
RF Power Components	67
RSE Ham Shack	61
Radio Amateur Callbook	49
Radio & Electronics Constructor	62
Ross Distributing Company	66
S-F Amateur Radio Services	60
SST Electronics	60
Swan Electronics	56, 57
Telrex Laboratories	49
Ten-Tec	77
Thomas Communications	54, 55
Tri-Ex Tower Corp.	31
Universal Manufacturing Corp.	61
Webster Associates	62
Western Electronics	61
Wilson Electronics	10

Foreign Subscription Agents for Ham Radio HORIZONS

Ham Radio Austria F. Basi Hauptplatz 5 A-2700 Wiener Neustadt Austria	Ham Radio Holland MRL Electronics Postbus 88 NL-2204 Delft Holland
Ham Radio Belgium Stereohouse Brusselsesteenweg 416 B-9218 Gent Belgium	Ham Radio Italy STE, Via Maniago 15 I-20134 Milano Italy
Ham Radio Canada Box 114, Goderich Ontario, Canada N7A 3Y5	Ham Radio Switzerland Karin Ueber Postfach 2454 D-7850 Loerrach West Germany
Ham Radio Europe Box 444 S-194 04 Upplands Vasby Sweden	Ham Radio UK P.O. Box 53, Harrow Middlesex HA3 6HS England
Ham Radio France Christiane Michel F-89117 Parly France	Ham Radio Holland Radio 143 Greenway Greenside, Johannesburg Republic of South Africa



HENRY RADIO ANNOUNCES THE TEMPO K6FZ* LOOP ANTENNA

**NOW YOU
DON'T HAVE TO BE
OFF THE AIR BECAUSE
YOU LIVE IN AN
APARTMENT, CONDOMINIUM,
BOAT, R/V, OR???**

At last! Now you can put a good signal on the air with an unobtrusive antenna. The Tempo K6FZ Constant Current Loop Antenna is basically for 20 meter operation, but with the addition of optional elements it also offers 10 and 15 meter capability. It is a totally new concept in quick assembly fiberglass antenna design. The K6FZ is a full half wavelength horizontal loop radiator only eight feet square. It exhibits forward gain, front-to-side and front-to-back ratios and uses no lossy inductive loading coils or traps.

Install it in a fixed position or rotate it with any inexpensive TV rotor. . . in the attic, on the roof, or hang it in a tree. Your neighbors will think it's just another FM or TV antenna. Wherever it ends up, you'll have fun getting on the air again.

Specifications (Typ 20 meter characteristics)

Gain: + 1 dB over dipole (full sized)
Impedance: 50 Ω balanced—balun recommended
(W2AU or BN86)
VSWR: Better than 2 to 1 over entire band
Polarization: Horizontal
Front-to-back ratio: 1.5 to 2 S units (9 to 12 dB)
Front-to-side ratio: 1.8 to 2.5 S units (10 to 15 dB)
Power rating: 2kw PEP

Dimensions: 8 feet (2.44 meters)
square; Shipping box 98 inches long
Turning radius: 5.8 feet (1.8 meters)
Weight: 10 lbs (4.55 kg)
Price: \$159.00

Accessories:

W2AU Balun \$14.95
15-K6FZ 15 meter adapter kit (TBA)
10-K6FZ 10 meter adapter kit (TBA)

*U.S. & Foreign Patents Pending

Sold at Tempo dealers throughout the U.S.
and abroad. Please call or write
for further information.

NEW TOLL FREE ORDER NUMBER: (800) 421-6631

For all states except California.
Calif. residents please call collect on our regular numbers.

Prices subject to change without notice

Henry Radio

11240 W. Olympic Blvd., Los Angeles, CA 90064 (213) 477-6701
931 N. Euclid, Anaheim, CA 92801 (714) 772-9200
Butler, Missouri 64730 (816) 679-3127

CALL TOLL FREE

1-800-228-4097
Communications Center
 443 N 48th Street
 Lincoln, Nebraska 68504
 In Nebraska Call (402)466-8402



Antenna Sale!

HY-GAIN

		Regular	Special			Regular	Special
TH6DXX	Super Thunderbird	\$299.95	\$239.95	18HT	Hy-Tower 80-10M vertical	299.95	239.95
TH3MK3	3 el. 10-15-20M beam	229.95	179.95	18AVT/WB	80-10M Trap vertical	99.95	79.95
TH3JR	3 el. 10-15-20M beam	149.95	129.95	14AVQ/WB	40-10M Trap vertical	69.95	57.00
Hy-Quad	2 el. 10-15-20M Quad	229.95	179.95	12AVQ	20-10M Trap Vertical	39.95	32.95
205BA	5 el. "Long John" 20M beam	289.95	229.95	14RMQ	Roof Mounting kit (verticals)	33.95	29.95
155BA	5 el. "Long John" 15M beam	169.95	139.95	5BDQ	80-10M Trap doublet	89.95	69.95
105BA	5 el. "Long John" 10M beam	119.95	99.95	2BDQ	80-40M Trap doublet	49.95	39.95
204BA	4 el. 20M beam	219.95	179.95	66B	6 el. 6M beam	119.95	99.95
204MK5	5 el. conversion kit	99.95	79.95	203	3 el. 2M beam	15.95	
153BA	3 el. 15M beam	79.95	69.95	205	5 el. 2M beam	17.95	
103BA	3 el. 10M beam	54.95	44.95	208	8 el. 2M beam	25.95	
402BA	2 el. 40M beam	209.95	169.95	214	14 el. 2M beam	31.95	
BN-86	Balun for beam antennas	15.95	15.95	LA-1	Deluxe lightning arrestor	59.95	49.95
TH2MK3	2 el. 10-15-20M beam	149.95	119.95				

MOSLEY

		Regular	Special
Classic 33	3 el. 10, 15, 20 Mtr. beam	304.75	209.95
Classic 36	6 el. 10, 15, 20 Mtr. beam	392.75	269.95
TA-33	3 el. 10, 15, 20 Mtr. beam	264.00	189.95
TA-36	6 el. 10, 15, 20 Mtr. beam	392.75	269.95
TA-33 Jr.	3 el. 10, 15, 20 Mtr. beam	197.00	149.95
TA-40KR	40 Mtr. Add On	119.95	89.95

CUSHCRAFT

ATB-34	4 ele. 10, 15, 20 Mtr. beam	289.95	219.95	A147-11	11 ele. 146-148 Mhz. beam	36.95	30.95
ATV-4	10, 15, 20, 40 Mtr. Vertical	89.95	69.95	A147-22	22 ele. Power Pack	109.95	89.95
ATV-5	10, 15, 20, 40, 80 Mtr. Vertical	109.95	89.95	A144-10T	2 Mtr. "Twist" 10 ele.	42.95	34.95
ARX-2	2 Mtr. Ringo Ranger	39.95	32.95	A144-20T	2 Mtr. "Twist" 20 ele.	62.95	52.95
AR-6	6 Mtr. Ringo	36.95	32.95	A147-20T	2 Mtr. beam	62.95	52.95
ARX-220	220 Mhz. Ringo Ranger	39.95	32.95	A430-11	432 Mhz. 11 ele. beam	34.95	29.95
ARX-450	435 Mhz. Ringo Ranger	39.95	32.95	A432-20T	430-436 Mhz. Beam	59.95	49.95
A144-11	11 ele. 144-146 Mhz. beam	36.95	30.95				

HUSTLER

3-TBA	3 ele; 10, 15, 20 Mtr. beam	259.95	189.95
4-BTV	10-40 Mtr. Vertical	99.95	79.95
5-BTV	10-80 Mtr. Vertical	134.95	99.95
RM-75	75 Meter Resonator	16.95	14.50
RM-75S	75 Meter Super Resonator	31.95	27.50
G6-144B	2 Mtr. Base Colinear	79.95	59.95
G7-144	2 Mtr. Base Colinear	119.95	89.95

WILSON

System One	5 ele. 10, 15, 20, Mtr. Beam	274.95	229.95
System Two	4 ele. 10, 15, 20 Mtr. Beam	219.95	179.95
System Three	3 ele. 10, 15, 20 Mtr. Beam	179.95	149.95
WV-1	10-40 Mtr. Vertical	79.95	69.95

ROTORS

Ham III \$125.00 T2X Tailtwister \$199.95 Alliance HD 73 \$109.95

Call for prices on rotor cable, Coax, Towers, and Accessories. All prices do not include shipping.

**We carry all major brands of ham radios
 AT DISCOUNT PRICES**

Yaesu — Kenwood — Drake — ICOM — Dentron —
 Ten-Tec — Swan — Tempo — Midland — E.T.O. — Wilson



TS-180S with DFC*



NEW!

Digital Frequency Control* ...a Kenwood innovation for maximum HF operating enjoyment!

Kenwood's TS-180S with DFC is an all solid-state HF transceiver designed for the DXer, the contest operator, and all other Amateurs who enjoy the 160 through 10-meter bands. The following features prove, beyond doubt, that the TS-180S is the classiest rig available!

- Digital Frequency Control (DFC), including four memories and manual scanning. Memories are usable in transmit and/or receive modes. Memory-shift paddle switches allow any of the memory frequencies to be tuned in 20-Hz steps up or down, slow or fast, with recall of the original stored frequency. It's almost like having four remote VFOs!
- All solid-state... including the final. No dipping or loading. Just dial up the frequency, peak the drive, and operate!
- High power... 200 W PEP/160 W DC input on 160-15 meters, and 160 W PEP/140 W DC on 10 meters (entire band provided). Also covers more than 50 kHz above and below each band (MARS, WARC, etc.), and receives WWV on 10 MHz.
- Improved dynamic range.
- Adaptable to all three proposed (WARC) bands.
- Single-conversion system with highly advanced PLL circuit, using only one crystal with improved stability and spurious characteristics.
- Built-in microprocessor-controlled large digital display. Shows actual VFO frequency and difference between VFO and "M1" memory frequency. Blinking decimal points indicate "out of band." Monoscale dial, too.
- IF shift... Kenwood's famous passband tuning that reduces QRM.
- Selectable wide and narrow CW bandwidth on receive (500-Hz CW filter is optional).
- Automatic selection of upper and lower sideband (SSB NORM/SSB REV switch).
- Tunable noise blanker (adjustable noise-sampling frequency).
- RF AGC ("RGC"), which activates automatically to prevent overload from strong, local signals.
- AGC (selectable fast/slow/off).
- Dual RIT (VFO and memory/fix).
- Three operating modes... SSB, CW, and FSK.
- Improved RF speech processor.
- Dual SSB filter (optional), with very steep shape factor to reduce out-of-passband noise on receive and to improve operation of RF speech processor on transmit.
- 13.8 VDC operation.
- Also available is the TS-180S without DFC, which still shows VFO frequency and difference between VFO and "hold" frequencies on the digital display.
- Full line of matching accessories, including PS-30 base-station power supply, SP-180 external speaker with selectable audio filters, VFO-180 remote VFO, AT-180 antenna tuner/SWR and power meter, DF-180 digital frequency control, YK-88 CW filter, and YK-88 SSB filter.

All of these advanced features can be yours... and at an attractive price! Visit your local Authorized Kenwood Dealer and inquire about the exciting TS-180S with DFC!



Still available...
Kenwood's TS-820S HF transceiver.



KENWOOD
...pacesetter in amateur radio

TRIO-KENWOOD COMMUNICATIONS INC.
1111 WEST WALNUT/COMPTON, CA 90220

Introducing the first price breakthrough in amateur radio equipment in a decade!



\$388

ATLAS 110 TRANSCEIVER

- Self-contained power supply and speaker
- All solid state
- Covers 10-80 meters
- 20 watt input power
(250 watt model available)
- SSB and semi-break-in CW with sidetone

True, it doesn't have all the bells and whistles, but it does two things extremely well:

It does an excellent job of receiving.

It does an excellent job of transmitting.

On both SSB and CW.

Compare the performance of the Atlas 110 with any other equipment on the market, and see for yourself: it is truly a high performance transceiver in every respect.

And it costs only \$388.

Also available is the Model 110 Special, which includes RIT, CW Filter, and RF Gain Control.

Both the 110 Standard and the 110 Special transceivers are available with either 20 watt or 250 watt power

input rating. (250 watt model requires a separate AC power supply.)

The receive portion of the 110 transceiver is also available separately, as the Atlas RX-110 receiver. The TX-110 transmit module may be added later.

20 W MODEL 110 STANDARD TRANSCEIVER . . . \$388

20 W MODEL 110 SPECIAL* TRANSCEIVER . . . \$428

(illustrated above)

250 W MODEL 110 STANDARD TRANSCEIVER . . . \$478

250 W MODEL 110 SPECIAL* TRANSCEIVER . . . \$518

PS-110H AC POWER SUPPLY . . . \$ 89

(required with 250 watt transceiver)

*Includes RIT, CW filter, RF Gain Control.

For complete details see your Atlas dealer or drop us a card and we'll mail you a brochure with dealer list.



ATLAS
RADIO INC.

417 Via Del Monte, Oceanside, CA 92054
Phone (714) 433-1983